



## **M44H Marine LED Beacon**

### **Product Manual**

**Version: 1.03**

**Date: March 13, 2023**

**SABIK Oy**

P.O. Box 19

FI-06151 Porvoo - Finland

Tel. +358-19-560 110

Fax +358-19-560 1120

E-mail [sales@sabik-marine.com](mailto:sales@sabik-marine.com)[www.marine.sabik.com](http://www.marine.sabik.com)**Product Warranty**

Sabik Oy warrants that all products supplied are free from labour and material defects, and will repair or replace (at its option) the whole or any part of the products found to be faulty. Sabik Oy is not liable for any charge beyond the point of delivery, including installation, alignment or testing. To claim under warranty the product must be returned to the manufacturer.

**Legal Notice**

Information in this document is subject to change without notice. Sabik Oy makes no warranty of any kind with regards to this material, including but not limited to, the implied warranties of merchantability and fitness for purpose. Sabik Oy shall not be liable for errors contained herein or for incidental or consequential damages in connection with the use of this material. No part of this document may be photocopied, reproduced, or translated to another language without prior written consent of Sabik Oy. The Vega logo is a registered trademark of Sabik Oy.

**M44H Marine LED Beacon**

Disclaimer: Every possible effort has been made to ensure the validity of this document. It represents the current view (as of the publishing date) on the functions and properties of the products mentioned in the document. Sabik Oy is not responsible for possible typing errors. The pictures and drawings are for descriptive use only.

The document may be updated or changed without notice.

# Table of Contents

- 1. INTRODUCTION TO THE M44H MARINE LED BEACON ..... 3**
  - 1.1. THE INITIAL POWER-UP .....3
  - 1.2. BLUETOOTH PROGRAMMING.....3
  - 1.3. INFRA-RED PROGRAMMING .....3
  - 1.4. AUTOMATIC EFFECTIVE INTENSITY CORRECTION.....4
  - 1.5. M44H INTENSITY PERFORMANCE.....4
  - 1.6. BEACON ON OVERRIDE.....5
- 2. INSTALLING THE M44H BEACON ..... 6**
  - 2.1. THE MOUNTING STRUCTURE .....6
  - 2.2. MOUNTING .....6
    - 2.2.1. *Base Mounting* .....6
    - Multi-* .....7
    - 2.2.2. *lantern assembly* .....7
  - 2.3. BIRD SPIKES.....8
  - 2.4. LIGHTGUARD LTE-M, REMOTE MONITORING UNIT .....8
- 3. POWER SUPPLY ..... 9**
  - POWER SUPPLY REQUIREMENTS.....9
  - POWER SUPPLY CONNECTION .....9
- 4. SYNCHRONIZATION WITH OTHER BEACONS ..... 10**
  - 4.1. HARD-WIRE SYNCHRONIZATION .....10
  - 4.2. GNSS SYNCHRONIZATION OPTION (OPT4E).....10
- 5. PROGRAMMING ..... 11**
- 6. ROUTINE MAINTENANCE ..... 19**
  - Inspection check*.....19
- APPENDIX A M44H-1T BEACON DIMENSIONS..... 3**
- APPENDIX B M44H-2T BEACON DIMENSIONS..... 4**
- APPENDIX C M44H-3T BEACON DIMENSIONS..... 5**
- APPENDIX D DUAL BEACON MOUNTING KIT..... 6**
- APPENDIX E THREE-BEACON MOUNTING KIT ..... 8**
- APPENDIX F PRODUCT CODES..... 10**

# 1. Introduction to the M44H Marine LED Beacon

The Sabik M44H LED beacon is an energy-efficient marine beacon that is available in one, two or three tier configurations. For maximum light output, up to three lanterns can be stacked on top of each other using an optional mounting bracket.

Nominal input voltage for M44H beacon is 24 VDC and maximum input voltage is 32 VDC. Reverse polarity protection is provided. Lantern power cable is 2 meters long.

M44H has many configurable features to adjust lantern operation according to requirements at different sites. These features are programmed using the Sabik Bluetooth™ app. Details for reprogramming the M44H are provided in the Sabik Bluetooth™ Control- and easyProgrammer product manuals.

M44H is high intensity lighthouse lantern and despite high efficacy, the lantern still has significant power consumption, especially when intensity setting is high and flash characters duty cycle is heavy. Therefore, special attention should be given for sizing the suitable power supply, solar panel and battery for the lantern. Adjusting lantern intensity, colour or flash character will affect the power consumption.

M44H Power and Intensity calculation software will help to determine exact power consumption according to the specific requirements at each location. It is available for download at the M44H product page in <https://marine.sabik.com/>. Sabik or the local Sabik Distributor can also assist with the calculation if required.

The M44H beacons are fitted with wire synchronization, which can be used to synchronize the flash character with other Sabik beacons that are within wiring distance. Optional satellite synchronization allow synchronization with remote beacons.

## 1.1. The initial power-up

Upon first powering-up the beacon will start in night mode. If the beacon is in the default mode then it will be operating with the programmed flash character.

- After power up the beacon will begin to monitor for the low battery threshold. If the input voltage is below the threshold then the beacon will be turned off. The beacon will not return to normal operation again until the battery charges to the high voltage reset value.
- After 30 seconds the beacon will begin to monitor the ambient light level. If day is detected and the beacon is set for night-only operation then the beacon will be turned off.

Note: If the beacon does not flash when power is connected.

- The power connection might be reversed. Check that the power connection is correct. The beacon is protected from damage for reverse-polarity connection.

## 1.2. Bluetooth programming

The lantern is equipped with Bluetooth as standard and Sabik provides an Android and IOS app free of charge. A Sabik LightGuard Monitor account is required to use the software. Please contact your local distributor or send an email to [support@sabik.com](mailto:support@sabik.com), if you don't have an account.

## 1.3. Infra-red programming

The infrared receiver for programming the beacon is located on the base of the beacon inside the photocell window. For best results when programming point the easyProgrammer at this part of the beacon. Refer to the separate instruction manual for operating the Sabik easyProgrammer.

## 1.4. Automatic Effective Intensity Correction

The M44H beacon is programmed for the required effective intensity. This is the intensity of a flashing light needed to appear as bright as a light that is continuously “on”. When a light is flashing, the intensity must be increased to maintain the visibility of the light at the required distance. The M44H automatically maintains the effective range of the light by adjusting the intensity when flash character is changed. This function correlates to the Modified Allard Method in accordance with the IALA Recommendation R0204.

## 1.5. M44H Intensity Performance

The M44H lantern is primarily designed to be used as a long-range Lighthouse beacon. Maximum effective intensity is available in full scale for typical Lighthouse flash characters. Where flash characters with heavier duty cycles are used, the lantern will automatically limit the maximum allowed intensity setting depending on lantern type and duty cycle. The figure below can be used as an indication of the available intensity range. Exact calculations are provided using the M44H Performance Tool, available for download at the M44H product page in <https://www.sabik-marine.com/>

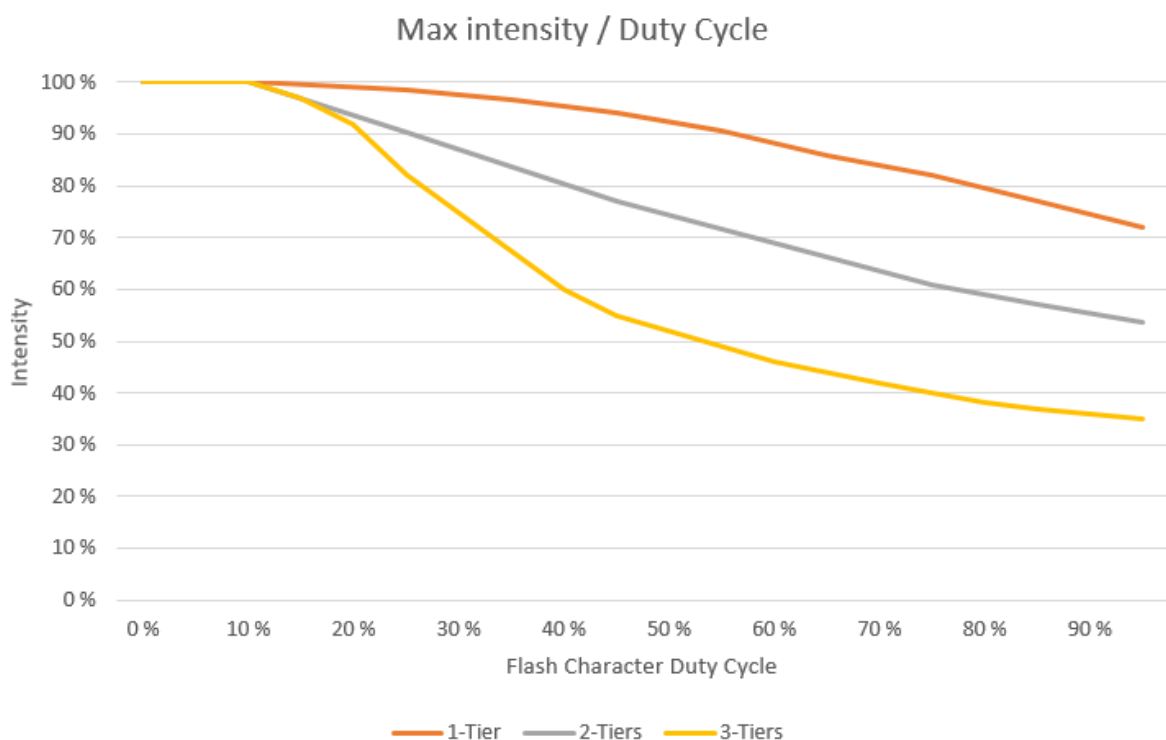

Additionally, the beacon cannot output an intensity above its maximum peak candela capability. When programming a flash character the user should check that the peak candela needed for the required effective candela is below the maximum peak intensity of the beacon. If higher peak intensity is required than what the M44H can produce then the beacon will not have the required range. Should this be the case the choice to achieve the desired range would be to:

- Increase the flash “on” period (select a different flash character) or
- Use a M44H beacon with additional tiers.

## 1.6. Beacon On Override

The M44H may be forced on by connecting the Sync input to battery negative. This input is not capable of turning the beacon off.

For example, if the beacon is configured to night only mode, activating the beacon from sync line during the day will cause the beacon to operate for as long as that input is held low. If the sync line is high or open circuit (i.e. inactive) then the beacon will operate normally, sensing day/night and switching automatically in the normal way.

NOTE! The Beacon On mode is disabled if the Cable Sync function is enabled.

- On/Off input - if this input is low ( $\leq 0.4V$ ) the beacon will turn on; if this input is open-circuit or high ( $> 6V$ ) then the beacon operates automatically according to its settings.

## 2. Installing the M44H Beacon

### 2.1. The Mounting Structure

Any movement of the mounting structure will affect how the intended user will see the beacon. The amount of sway that can occur needs to be limited to ensure that the beacon will remain visible. The vertical divergence of the beacon is the point where the intensity is at 50% of the peak intensity. The M44H has 50% of the peak intensity 1.25° above and below the focal plane of the beacon. At twice the vertical divergence ( $\pm 2.5^\circ$ ) the intensity will be approximately 10% of the peak intensity.

### 2.2. Mounting

The M44H beacon should be carefully levelled to ensure that the focal plane of the beacon is horizontal. The focal plane of the beacon is parallel with the base. This levelling can be done by placing a builder's level across the mounting surface of the structure, then moving the level 90 degrees to check the surface is level in at least two directions. If the mounting surface is not level take appropriate measures to ensure it is level before permanently fixing the beacon.

An alternative option is to use a levelling mechanism, such as adjustable rods to level the base of the beacon.

#### 2.2.1. Base Mounting

The M44H supports both 3- and 4-hole base mounting.

The holes on the base are  $\varnothing 14\text{mm}$  in diameter and located on a 200mm PCD. The beacon can be secured using M12 (or 1/2" UNC) 316-grade stainless steel bolts or threaded rod.

Plastic isolation bushes have been fitted in the mounting holes to prevent bi-metallic corrosion occurring. Please ensure that these bushes remain in place and that the mounting bolts are **not over-tightened** as this may cause the base to make contact with the mounting surface and defeat the purpose for having the bushes fitted.

The beacon can be levelled using adjustable rods. Fit the mounting rods firmly in place on the mounting surface; place one nut and washer on each stud. Slip the beacon (with corrosion isolation bushes in place) over the studs, and adjust the nuts by hand until the beacon is level. Then add the top washers and locking nuts and tighten.

A	M12 Stainless Steel Stud
B	Locking Nut
C	Stainless Flat Washer (2)
D	Plastic Bush (2)
E	Beacon Base
F	Plain Nut
G	Mounting Base plate

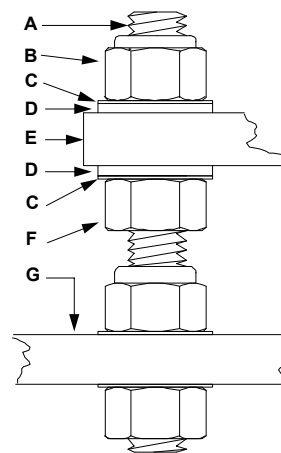

## 2.2.2. Multi-lantern assembly

Multi-lantern assembly can be used to increase the intensity beyond what can be reached with a single light or as a main / standby lantern pair for increased reliability.

M44H comes with a wire sync port as standard. Using the sync port several lanterns can operate as one single lantern. Alternatively, the sync port can be used to create a main and standby lantern pair.

The Ø80mm hole through the centre of the M44H beacon provides an alternative mounting option for stacking multiple lanterns as one assembly. Two mounting kits are available, one for stacking two lanterns and one for a three-lantern assembly.

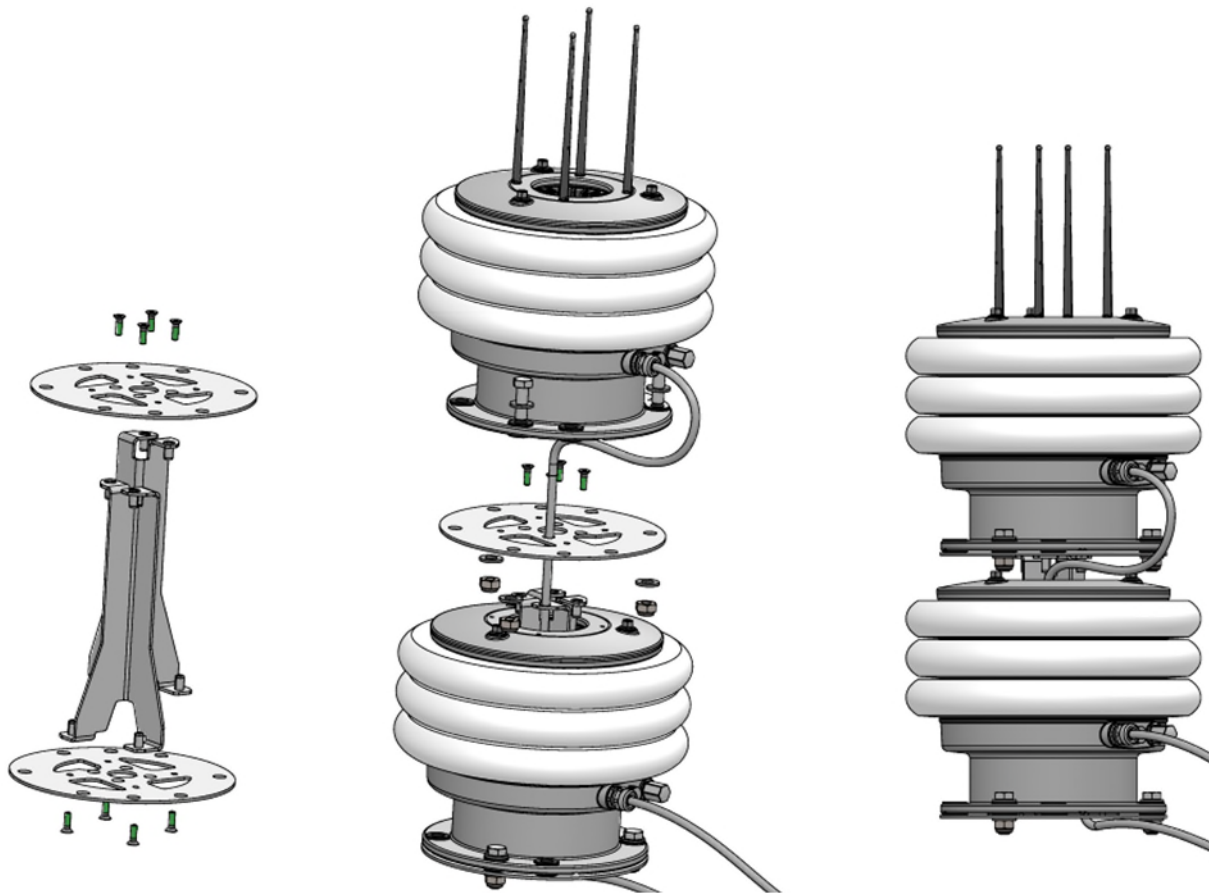



## 2.3. Bird Spikes

The beacon is supplied with four plastic bird spikes. To install the bird spikes simply screw them by hand into the threaded holes in the beacons lid. In case the beacon was ordered with LightGuard Remote Monitoring, please do not install the bird spikes. The LightGuard unit will be mounted using the same mounting holes and it comes with stainless steel bird spikes that replaces the original bird spikes.

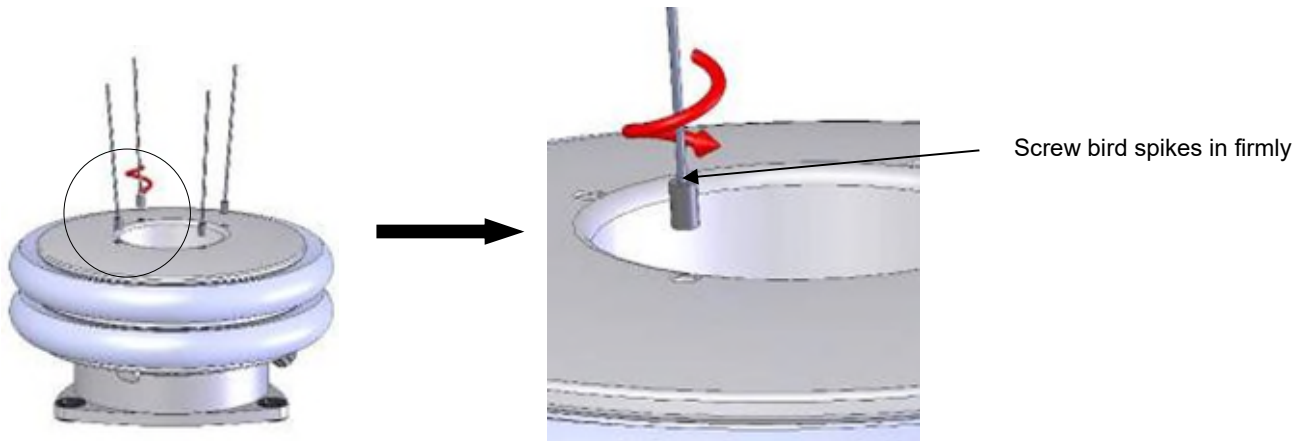

## 2.4. LightGuard LTE-M, remote monitoring unit

Screw the LightGuard remote monitoring to the mounting bracket using the screws included in the shipment. The bracket is to be mounted on top of the beacon as shown in the figure below. Route the supply cable through the center hole and connect the plug to the LightGuard unit before mounting it.

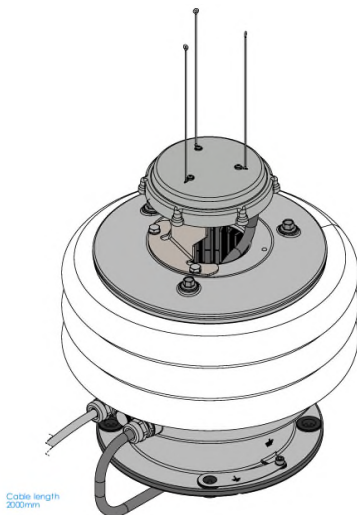

The LightGuard unit is pre-configured and will connect automatically to the LightGuard Monitoring, LGM, web portal at <https://lgm.sabik.com>

### 3. Power Supply

#### Power Supply Requirements

M44H is high intensity lighthouse lantern and despite high efficacy, the lantern still has significant power consumption, especially when intensity setting is high and flash characters duty cycle is heavy. Therefore, special attention should be given for sizing the suitable power supply, solar panel and battery for the lantern. Adjusting lantern intensity, colour or flash character will affect the power consumption.

Supply voltage is nominally 24 VDC, with an operating range of 20.0 – 32.0 VDC. Normal operating voltage should never exceed 35.9V. Reverse polarity and internal transient voltage protection are provided.

A low and high voltage threshold is programmable and the beacon will switch off if the low threshold is reached. This feature is provided to prevent the total discharge of a battery if it is being used as the power source. The default low voltage threshold is 20 Volts.

Where possible do not earth any of the supply wiring such as the battery negative. This precaution may avoid setting up additional electrical current paths that could cause metallic corrosion. Connect only the earthing point of the beacon to ground.

#### Power Supply Connection

The M44H is supplied with a 2 metre cable already sealed into the cable gland. If the power cable is shortened, ensure that the cable is resealed using heat shrink and marine sealant at the cut to prevent any moisture being able to enter the beacon.

Wire numbers	Net	Voltage	Polarity
1, 3	Vin+	+24 Volts	Battery positive
2, 4	Vin-	0 Volts	Battery negative
5	Sync	0 to 10 Volts	

An external fuse has to be included at the power supply connected to the lantern Vin+ input power port. Please see the table below for a suitable fuse size depending on the model in use.

Lantern model	Suitable fuse size
1 Tier	16 A
2 Tiers	25 A
3 Tiers	40 A

## 4. Synchronization with Other Beacons

### 4.1. Hard-wire synchronization

The M44H beacon comes with a sync wire to allow synchronizing with other beacons that are within a reasonable wiring distance.

When synchronizing, the start of the flash character can be delayed between 0s and “the total flash character duration – 0.05s” after the sync pulse.

### 4.2. GNSS synchronization option (OPT4E)

The M44H beacon can operate with an optional GNSS sync unit. It will allow the beacon to synchronize with other beacons being controlled by a compatible GNSS sync pulse. Please follow the installation procedure as with the LightGuard remote monitoring unit as described in chapter 2.4.

On synchronization, the start of the flash character can be delayed between 0s and “the total flash character duration – 0.05s” after the sync pulse.

The synchronization unit can be mounted on top of the beacon by routing the cable through the centre hole of the beacon.

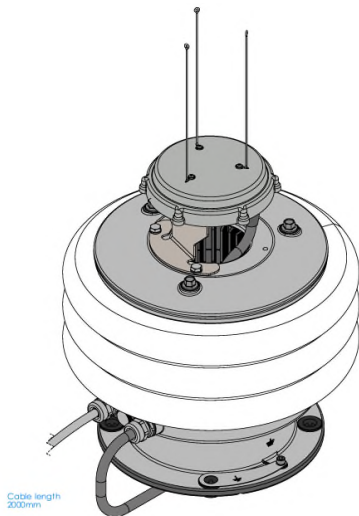

5.

## 5. Programming

The lantern is equipped with Bluetooth as standard. A legacy infrared port is provided underneath the venting plug. The infrared port is compatible with Sabik easyProgrammer.

### Bluetooth Control App

The Product is designed for programming and controlling Sabik Bluetooth® enabled lanterns using a simple user-friendly interface. The Android or iPhone app can be downloaded and installed to Bluetooth® 4.0 (Bluetooth® Smart) capable smart phone. The useable range between lantern and phone is usually more than 10m (the range is depending on type of lantern) and maximum up to 50m. The energy consumption of the Bluetooth® chip is very low. These instructions are for Android devices but the instructions for iPhone are very similar.

#### Standard Features and requirements



The lantern settings can be read to your phone for monitoring purposes. If you have the access rights you also can make changes and send them to the lantern. You cannot store the settings on your phone.

The app requires a minimum of iPhone 4s or a Bluetooth® 4.0 (Bluetooth® Smart) capable Android phone with operating system 4.3 or higher.

### Installation

The app can be downloaded from Apple (<http://store.apple.com>) or Google (<https://play.google.com>) for free. Observe, that you may have to register yourself before downloading. The app is free of charge.

#### Installation

Follow the instructions on Google or Apple Store

#### Registration

For the application to be able to work, you have to register your application using a valid user name and a password. Please contact your dealer to obtain these. This procedure has only to be done once.

## Launching the application

After the installation, you should find an icon for the Bluetooth® app. You may relocate it if necessary.

## Login and selecting lantern

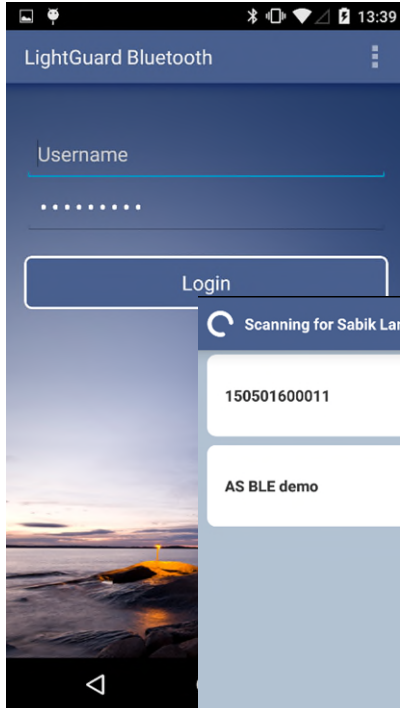

Fill in your user name and password and tap “Login”.

-if you don't have a user name and password, please contact your dealer to obtain these.

This information is stored in your device so the next time you will be logged in just by tapping the “Login” button

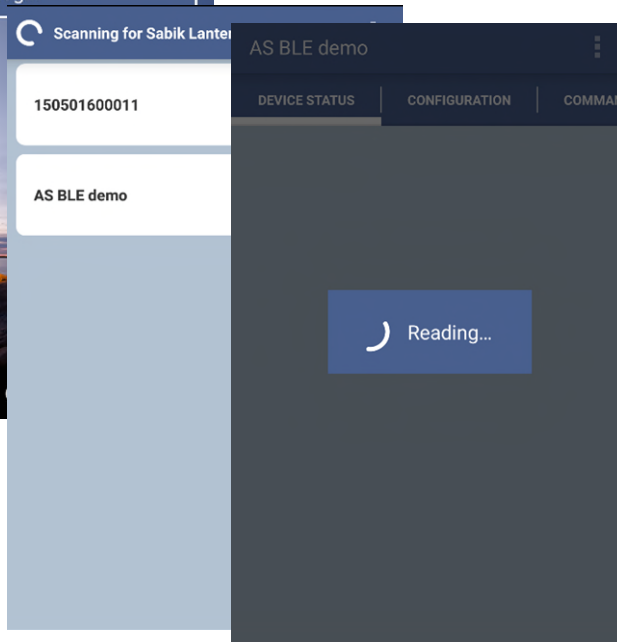

Now the app will search for Sabik lanterns within Bluetooth® range and display them in a list. Any lantern which is connected to another user will not be shown in the list. The lantern serial number is the default Bluetooth® name. This name can be changed using the application. This default serial number is also printed on the lantern. Tap on the name to select it.

## User interface

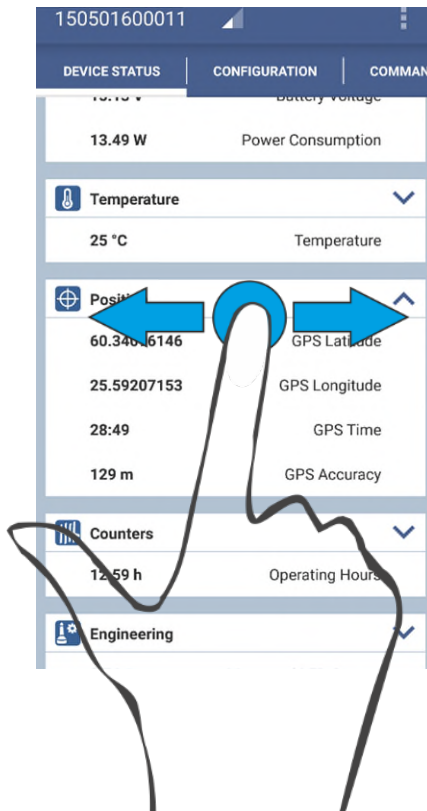

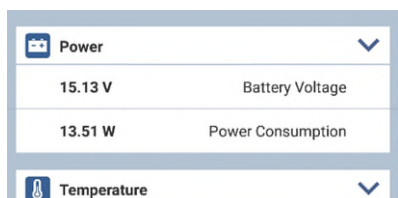

The interface labels are loaded from the lantern, so only the parameters relevant to this lantern are displayed. For instance, if there is no GPS function in the lantern, none are displayed in the application. The pages shows the standard settings.

The user interface is divided into screens. (DEVICE STATUS, CONFIGURATION, COMMANDS and ABOUT) To select a screen, swipe the screen to the right or left or tap a screen tab.

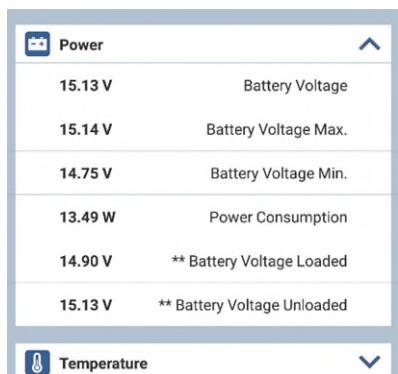

The Screens are divided into expandable blocks (Light, Power, Temperature etc.).For advanced settings, you have to expand the blocks. To expand a block just tap the  symbol near the right edge



Expanded view for advanced settings. Tap the  symbol to collapse.



On the **CONFIGURATION** page, you can change the lanterns configuration by tapping the small >-shaped symbol on the right side of the setting's name. If needed, expand the block to see the advanced settings.

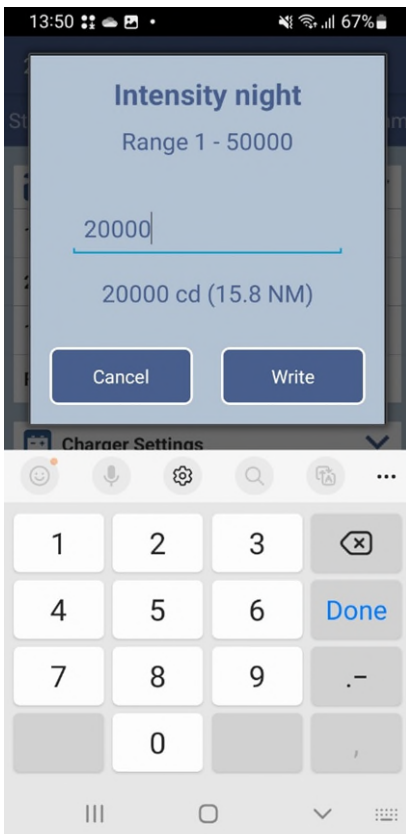

When, for example, Intensity is selected, you will be able to adjust the intensity by writing the effective intensity setting in candelas. For convenience, the app will show the corresponding range in nautical miles.

Tap Cancel to cancel or Write to send the updated value to lantern. The edited parameter is immediately stored in the lantern and the new value flashes briefly after it has verified by the lantern.

If the set value is too high or low, a warning message is shown and the value cannot be stored.

## Pages

On the pages you will find information about the lantern, change settings and send commands. Observe that if your lantern do not have a specific module installed, then there is no information about that module.

## DEVICE STATUS

Here you will find information about the Light, Power, Temperature, Position, Counters and Engineering values. You cannot make any changes to the lantern from this page. Observe that some values/settings may not be available in your lantern.

### Light

Light Status:	Shows the current light status, Active/Idle
Lantern Health Status:	Any possible error or warning is shown in the health status
Photocell Value:	Shows the real-time photocell value
Day-to-Night:	Latest transition time from day mode to night mode
Night-to-Day:	Latest transition time from night mode to day mode

### Power

Battery Voltage	Real time battery voltage
Battery Voltage Max	Maximum battery voltage during the last 24h
Battery Voltage Min	Minimum battery voltage during the last 24h
Battery Voltage Avg	Average battery voltage during the last 24h
Power Consumption:	Real time power consumption (measured only when light is lit)

### Temperature

Temperature	Real time temperature
Max. Temp. 24h	Maximum temperature during the last 24h
Min. Temp. 24h	Minimum temperature during the last 24h
Avg. Temp 24h	Average temperature during the last 24h

### Position (If GPS module installed)

GPS Latitude	Latest measured latitude position
GPS Longitude	Latest measured longitude position
GPS Time	Time of last fix
GPS Accuracy	GPS horizontal dilution of precision

### Counters

Operating Hours	Total illumination time
Power Cycle Counter:	Indicates the number of times power has been removed from lantern
System Reset Counter:	Number of reboots

### Engineering

Measured LED Current
Measured LED Voltage
Lantern Tilt Angle



## CONFIGURATION

On this page you can review and change the values of the Flasher, Charger, GPS & Sync, Tilt and Impact, Dated Shutdown and Bluetooth® Settings. Tap Write button to send new values to the lantern. The advanced settings are shown in *italics*

### Flasher

Flash Character: Select a standard flash character or create a custom flash character.  
 Effective Intensity: Change LED Intensity in effective intensity  
 Photocell Threshold: Lantern operating ambient light threshold in lux  
 Light Mode: Lantern operating mode (Photocell, Forced Idle, Forced Active or Day Lantern)

#### *Advanced Settings*

*LED Current:* **Product specific setting that must not be changed!**  
*Photocell Hysteresis:* *Hysteresis setting for turning off the lantern (lux)*  
*Astro Offset Sunrise:* *Offset for turning lantern off when in Astro mode (min)*  
*Astro Offset Sunset:* *Offset for turning lantern on when in Astro mode (min)*  
*Lantern Type:* *Lantern Installation Type (Stand alone, Primary or Standby)*  
*Event log:* *Enable (Yes) or disable (No) the Event log*

### Charger Settings

Minimum Battery Voltage: Minimum Voltage level for light operation.  
*Advanced Settings*  
*Cut In Voltage:* *Set minimum voltage for start charging.*  
*Cut Out Voltage:* *Set voltage for charger to stop charging.*  
*Charging Mode:* *Set charging mode (On/Off or PWM charging)*  
*Battery Hysteresis:* *Battery reconnecting hysteresis (V)*  
*Battery Temp. Compensation:* *Charging temperature compensation (-mV/°C)*  
*Boost Charge Hysteresis:* *Set boost charge compensation (V)*

### GPS & Sync

Max Distance from fixed: Max drift distance from GPS fix (meters)  
 Fixed Latitude: Set fix Latitude  
 Fixed Longitude: Set fix Longitude  
 GPS Check-up Interval: Set position check-up interval (min).  
 GPS Check-up Duration: Set position check-up duration (min)  
 Sync Setting: Set lantern Sync mode (Off, Cable, GPS or Cable and GPS)  
*Advanced Setting*  
*Sync Delay:* *Set Sync Delay (sec)*

## Tilt and Impact

Tilt angle Limit:	Set maximum allowed tilt angle (deg) before shutdown occurs.
<i>Advanced Setting</i>	
<i>Shutdown if tilted:</i>	Set lantern to shut down if tilted (Yes or No)

## Dated Shutdown

Dated Shutdown Enabled: Enable or disable dated shut down (Yes or No)

### *Advanced Settings*

<i>Shutdown Date:</i>	<i>Set date to shut down lantern</i>
<i>Startup Date:</i>	<i>Set date to start up lantern</i>

## Bluetooth Settings

Bluetooth Device name: Set lantern's Bluetooth name

### *Advanced settings*

<i>PIN Code Enabled:</i>	<i>Enable or disable lantern PIN code (give PIN code to change setting)</i>
<i>PIN Code:</i>	<i>Set new PIN Code</i>

## COMMANDS

On the COMMANDS page you can do a lantern test and download the event log.

### **Test Lantern**

The Test command runs the lantern for 3 minutes.

### **Download event log**

This command will download the full event log to your phone. You can now save it or share it.

## Create a custom Flash Character; Step by Step Instructions

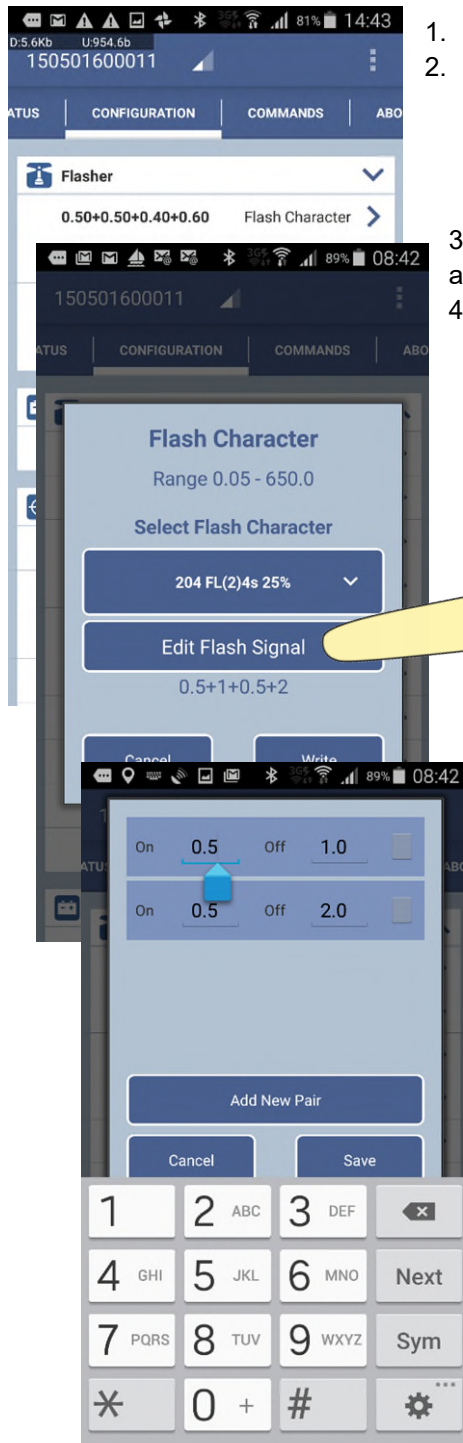

1. Select CONFIGURATION page
2. Tap on > symbol to the right of Flash Character
3. Select an existing Character from the list as a starting point and
4. Tap "Edit Flash Signal" to customize the character.
5. Change the On/Off timing. If needed add a new On/Off Pair or delete an existing pair by tapping the gray X. Tap Save, when done.
6. The new character will be saved as Custom.

## 6. Routine Maintenance

This LED beacon requires little to no maintenance other than the occasional cleaning with warm soapy water. Rinse off with clean water. Do not use any solvent-based cleaner.

If the beacon is solar powered, panels should be inspected and cleaned occasionally to ensure maximum solar energy capture. Battery capacity should also be monitored.

### Inspection check

- Periodically check that the beacon remains firmly secured and level, and that the mounting fasteners are still in good condition. Investigate any corrosion and take appropriate preventive action
- If the beacon is flashing, check that it is displaying the correct flash character. This can be tested by programming the “test” mode or if daytime covering the daylight sensor briefly to simulate night time operation. Note! Remember to remove any daylight sensor cover before leaving the site.
- Always monitor and maintain the beacon properly to ensure its continuous functioning. Note! A non-working AtoN may result in severe consequences up to loss of life at seas.





## Appendix A M44H-1T Beacon Dimensions

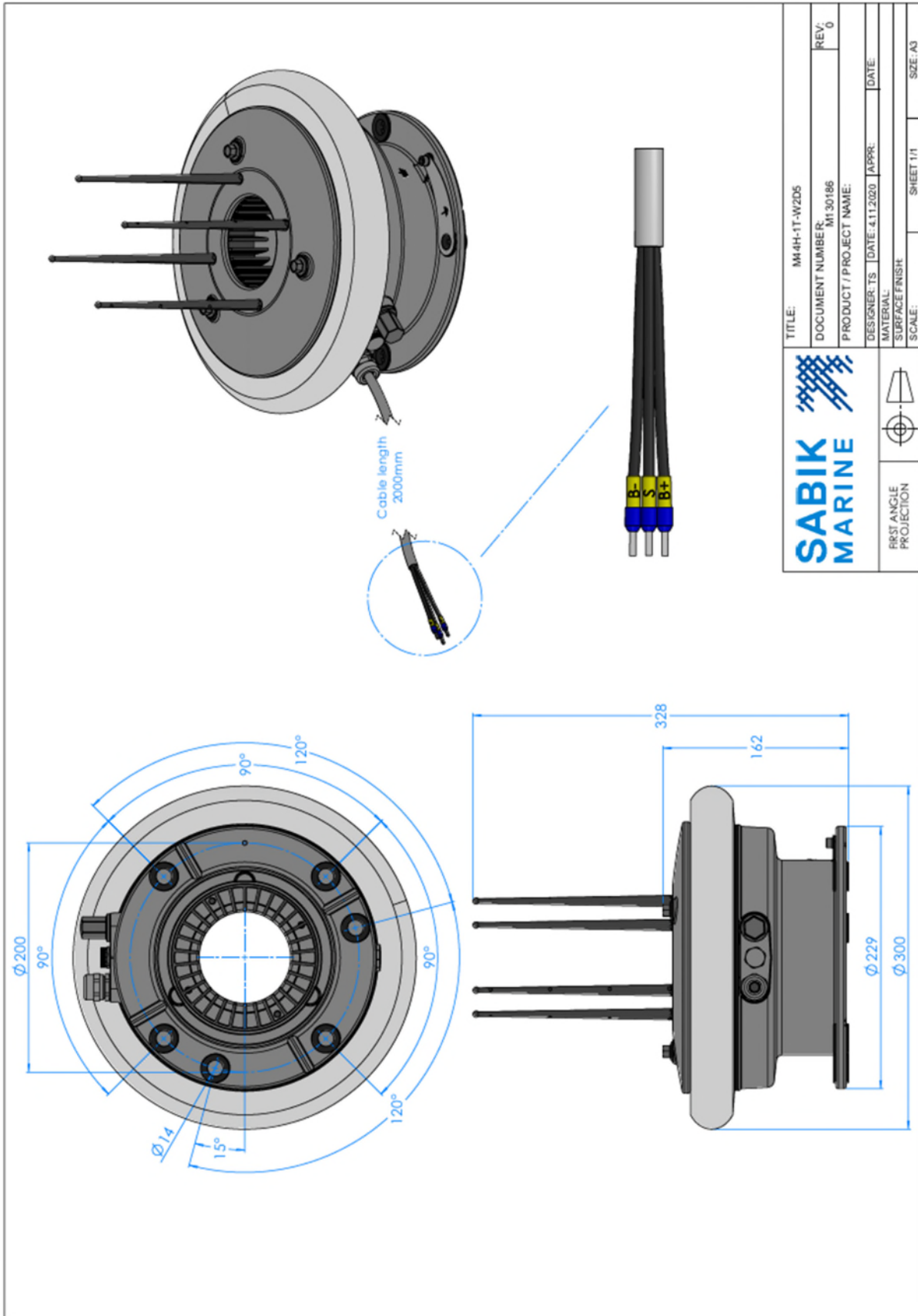

## Appendix B M44H-2T Beacon Dimensions

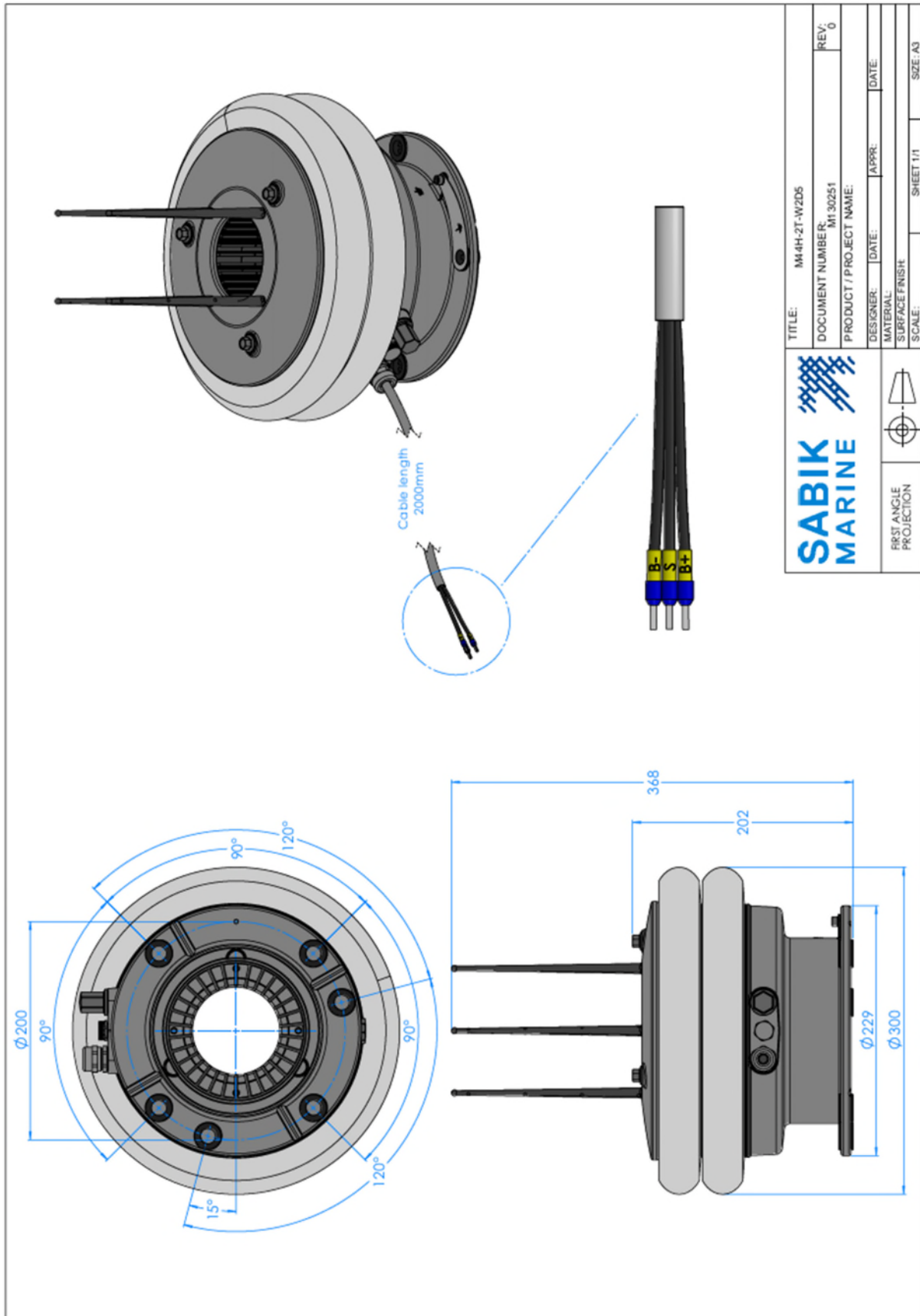

TITLE: M44H-2T-WZDS		REV: 0
DOCUMENT NUMBER: M130251		
PRODUCT / PROJECT NAME:		
DESIGNER:	DATE:	APPR: DATE:
MATERIAL:		
SURFACE FINISH:		
SCALE: SHEET 1/1		SIZE: A3





## Appendix C M44H-3T Beacon Dimensions

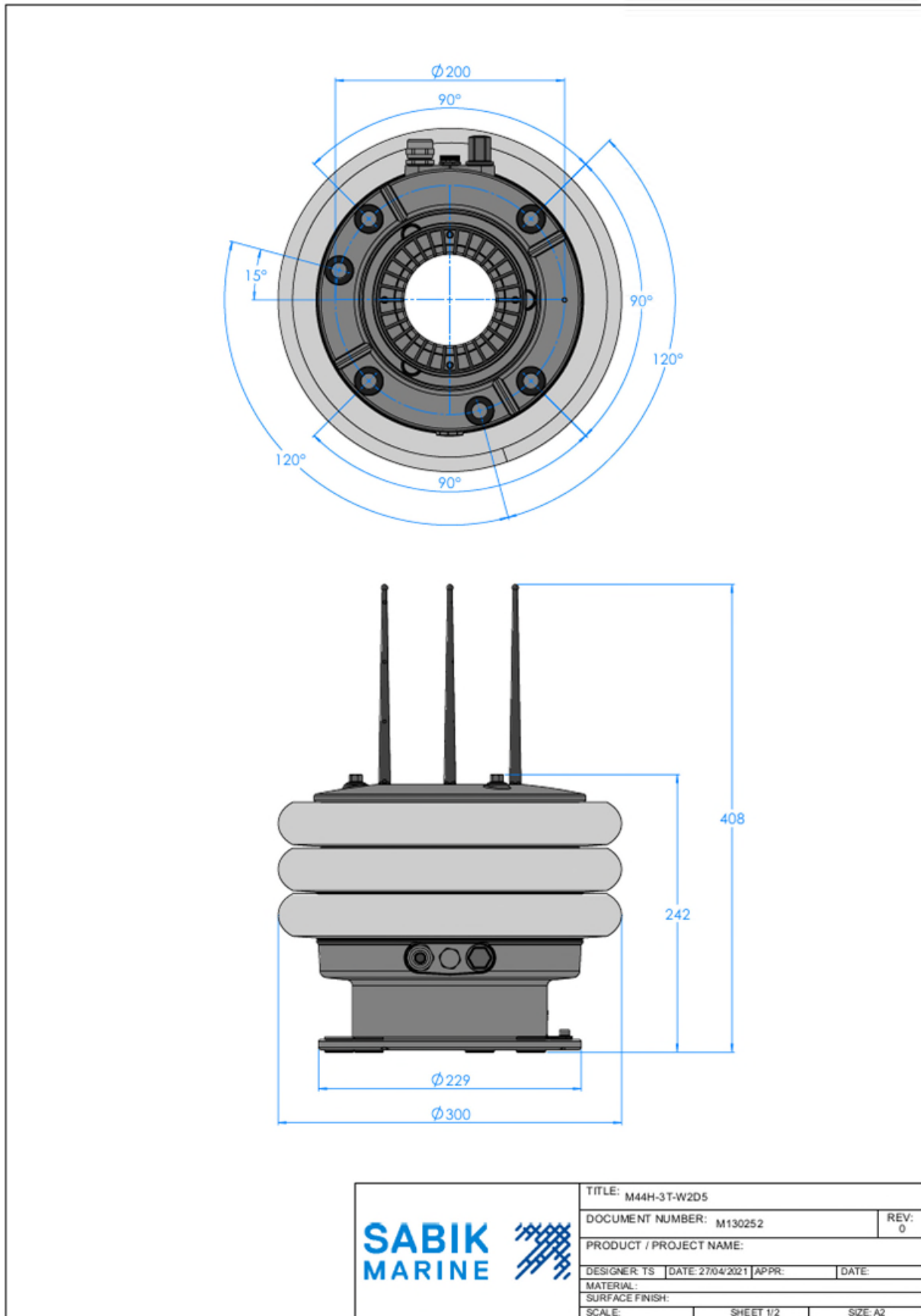

# Appendix D Dual Beacon mounting kit

Inserting the 3 Layer M44's



Part	Document Number	Title	Material	Revision
1	M132204	Lantern Stack Stand Plate	AlSi 316	0 2
2	M132223	3 Layer Lantern Stack Stand Pillar end M6 draft nut		0 2
3	M100388	Hexagon socket countersink head screw M8x60 DNF 991	A4	- 8
4	M10405	Washer M12 DNF 125	A4	- 12
5	M132208	Hexagon head bolt M12x35 DNF 931 A4	A4	- 6
6	M100937	Prevailing hexagon nut M12 DNF 965 A4	A4-80	- 6
7	M130262	MMH-3T-H2D5		A 2

**SABIK MARINE**

TITLE: Stand 2xM4H 3-Tier  
 DOCUMENT NUMBER: M132279-ASM  
 REV: 0

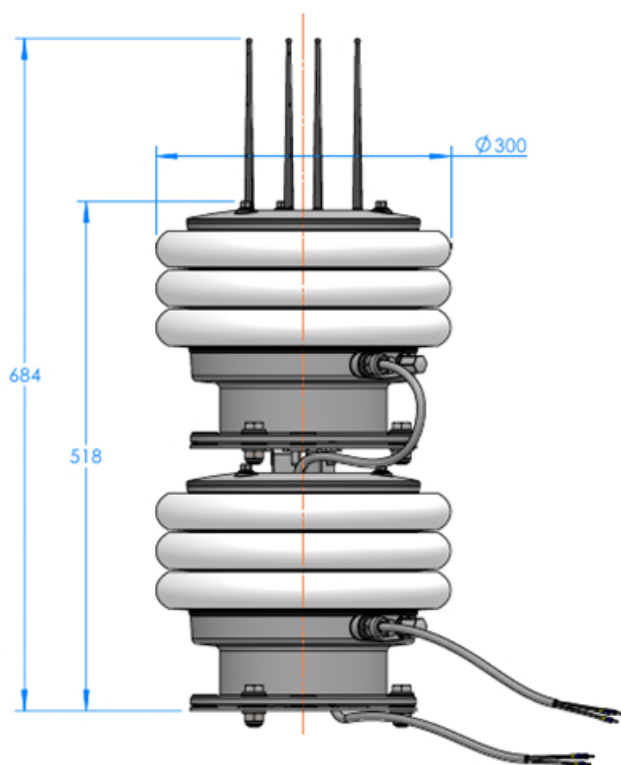
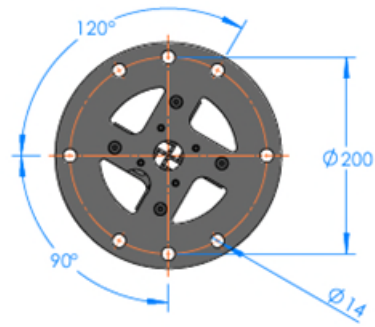
DESIGNER: SSK DATE: 15.09.2021  
 PRODUCT / PROJECT NAME:  
 MATERIAL:  
 SURFACE FINISH:  
 SCALE: 1:1  
 SHEET 13



<small>COMPANY CONFIDENTIAL: INFORMATION CONTAINED HEREIN IS CONFIDENTIAL. IT IS THE PROPERTY OF SPX CORPORATION. IT IS TO BE USED SOLELY FOR THE PURPOSES PROVIDED, AND IT IS NOT TO BE DISCLOSED TO OTHERS WITHOUT THE PRIOR WRITTEN CONSENT OF SPX CORPORATION.</small>			
		TITLE: Stand 2xM44H 3-Tier	
		DOCUMENT NUMBER: M132279-ASM	REV: 0
FIRST ANGLE PROJECTION		DESIGNER: sjs   DATE: 15.09.2021	
		MATERIAL:	
		SURFACE FINISH:	
All rights to changes reserved		SCALE:	SHEET 2/2
		SIZE: A2	

# Appendix E Three-Beacon mounting kit

REV. 01
DATE: 15.09.2021
SCALE: 1:2

Inserting the "3 Layer M44's"

Part Number	Document Number	Title	Material	Revision
1	M132204	Lantern Stack Stand Plate	ANSI 316	0 3
2	M132220	3 Layer Lantern Stack Stand Pillar, incl. M6 draft nut		0 4
3	M100388	Hexagon socket countersink head screw M6x20 DIN7991	A4	- 16
4	M100405	Washer M12 DIN125	A4	- 18
5	M132208	Hexagon head bolt M12x35 DIN931 A4	A4	- 9
6	M100937	Prevailing hexagon nut M12 DIN 985 A4	A4-80	- 9
7	M130252	M44H-3T-W205		A 3

**SABIK MARINE**

TITLE: Stand 3M44 3-Tier  
 DOCUMENT NUMBER: M132231-ASM  
 PRODUCT / PROJECT NAME: RUG  
 DESIGNER: [blank] DATE: 15.09.2021  
 SURFACE FINISH: [blank]  
 SCALE: SHEET 1/2 SIZE: A2

COMPANY CONFIDENTIAL - INFORMATION CONTAINED HEREIN IS CONFIDENTIAL & IS THE PROPERTY OF SABIK CORPORATION. IT IS TO BE USED ONLY FOR THE PURPOSES INDICATED AND IS NOT TO BE DISCLOSED TO OTHERS WITHOUT THE PRIOR WRITTEN CONSENT OF SABIK CORPORATION.

First Angle Projection  
 All rights reserved

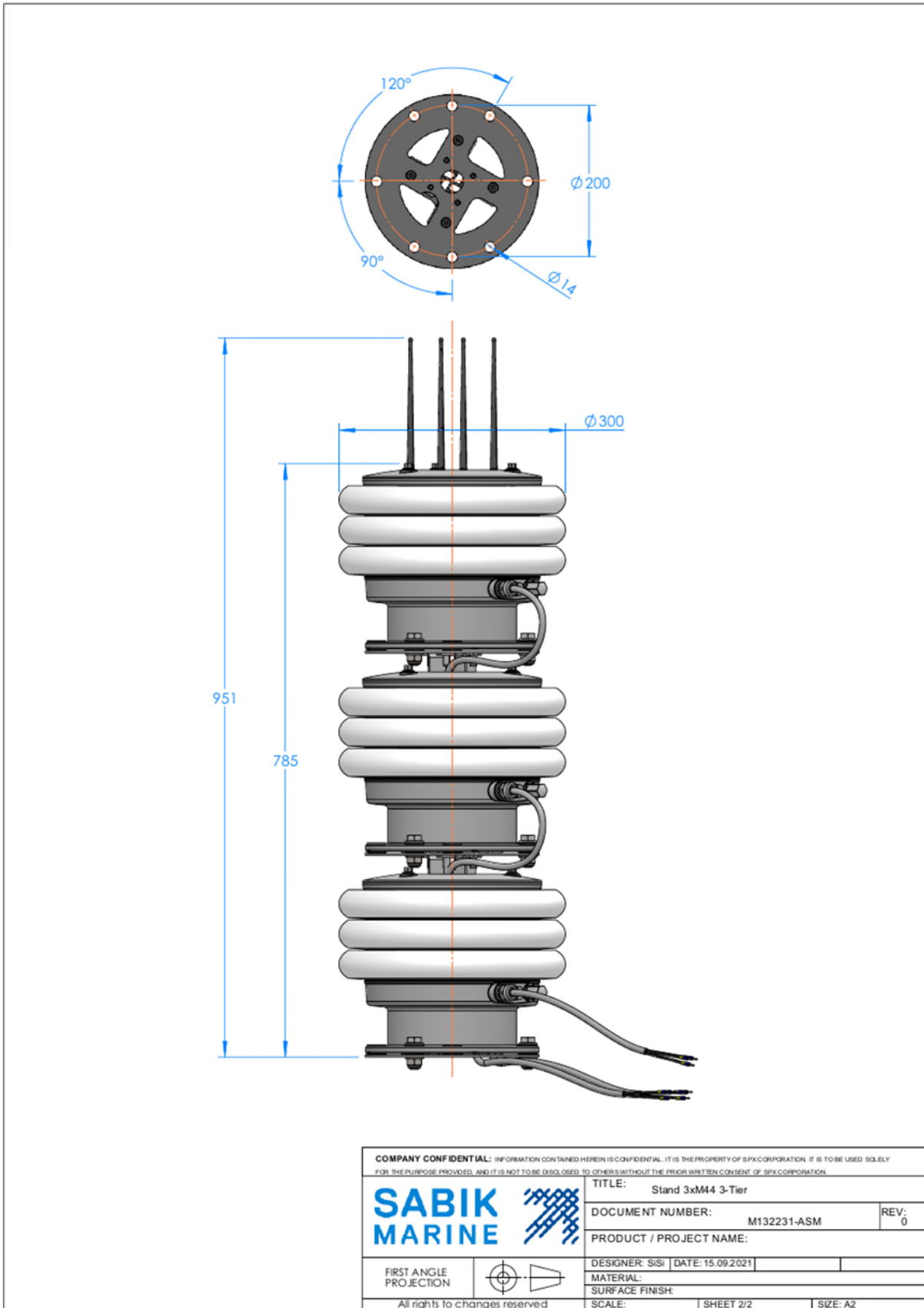

<small>COMPANY CONFIDENTIAL: INFORMATION CONTAINED HEREIN IS CONFIDENTIAL. IT IS THE PROPERTY OF SPX CORPORATION. IT IS TO BE USED SOLELY FOR THE PURPOSE PROVIDED, AND IT IS NOT TO BE DISCLOSED TO OTHERS WITHOUT THE PRIOR WRITTEN CONSENT OF SPX CORPORATION.</small>			
<b>SABIK MARINE</b> 		TITLE: Stand 3xM4 3-Tier	
		DOCUMENT NUMBER: M132231-ASM	REV: 0
FIRST ANGLE PROJECTION 		DESIGNER: SiSi   DATE: 15.09.2021	
All rights to changes reserved		MATERIAL: SURFACE FINISH:	
		SCALE:	SHEET 2/2   SIZE: A2

## Appendix F Product Codes

M44H-nT-c2D5-OPT	c	=	Beacon colours, R=RED, W=WHT
	2D5	=	Vertical divergence 2.5°
	n	=	Number of tiers
	OPT4E	=	GNSS synchronization
	OPT9E	=	LTE-M (GSM) LightGuard remote monitoring and GNSS sync
	OPT8E	=	Globalstar (satellite) LightGuard remote monitoring and GNSS sync

Mounting studs required: 3 or 4 M12 Bolts, nuts, washers, lock nuts (or 1/2")

3 or 4 M12 Threaded rod, nuts, washers, locking nuts (1/2")

Mounting bolt separation 200mm PCD