

Manual Revision	Description of Change	Date manual released	Made by
1.0	Initial version	4. Jan 2022	JoL
1.1	Updated to latest drawings and performance figures	27.4.2023	JoL

Disclaimer: Every possible effort has been made to ensure the validity of this document. It represents the current view (as of the publishing date) on the functions and properties of the products mentioned in the document. SPX Aids to Navigation Oy is not responsible for possible typing errors. The pictures and drawings are for descriptive use only.

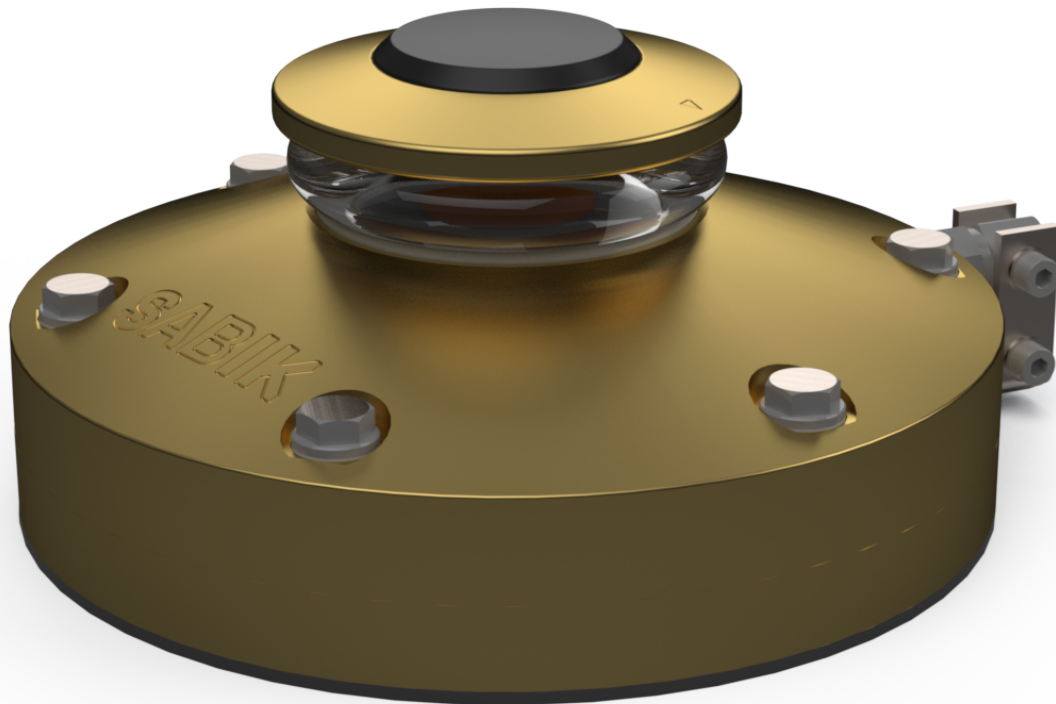

MPV2 **Ice-Buoy Lantern**

Installation, Operation and Programming Manual

Version: 1.1
Date: April 27, 2023

SPX Aids to Navigation Oy

P.O. Box 19

FI-06151 Porvoo - Finland

Tel. +358-19-560 110

Fax +358-19-560 1120

E-mail sales@sabik-marine.comwww.marine.sabik.com**Product Warranty**

SPX Aids to Navigation Oy warrants that all products supplied are free from labour and material defects, and will repair or replace (at its option) the whole or any part of the products found to be faulty. SPX Aids to Navigation Oy is not liable for any charge beyond the point of delivery, including installation, alignment or testing. To claim under warranty the product must be returned to the manufacturer.

Legal Notice

Information in this document is subject to change without notice. SPX Aids to Navigation Oy makes no warranty of any kind with regards to this material, including but not limited to, the implied warranties of merchantability and fitness for purpose. SPX Aids to Navigation Oy shall not be liable for errors contained herein or for incidental or consequential damages in connection with the use of this material. No part of this document may be photocopied, reproduced, or translated to another language without prior written consent of SPX Aids to Navigation Oy. The Vega logo is a registered trademark of SPX Aids to Navigation Oy.

**MVP2 Ice-Buoy Lantern**

Contents

1 INTRODUCTION	4
2 TECHNICAL DETAILS	5
2.1 OPTICAL PERFORMANCE	5
2.2 ENERGY CONSUMPTION	6
2.3 MECHANICAL	6
2.4 ELECTRICAL	7
2.5 LIGHT SENSOR.....	8
2.6 EMC	8
2.7 ENVIRONMENTAL	9
3 OPTIONAL MODULES	9
3.1 DATED SHUT-DOWN	9
3.2 LTE-M LIGHTGUARD MONITORING	9
3.3 GPS SYNCHRONIZATION ONLY	10
3.4 EVENT-LOG	10
4 COMMISSIONING	10
4.1 CONFIGURE LIGHT COLOUR	10
4.2 VARIOUS POWER SUPPLIES	11
4.2.1 Primary Battery	11
4.2.2 Other DC Power Supply	11
4.3 INSERT SIM CARD (ONLY LANTERNS WITH GSM MODULE)	12
4.4 PROGRAMMING	12
5 PERIODIC MAINTENANCE	21
6 TROUBLESHOOTING	22
7 APPENDIXES	23
7.1 EXPLOSION VIEW	23
7.2 PART LIST	24

1 Introduction

Standard features

- Designed for heavy-duty ice conditions
- Wide 10° vertical divergence
- Up to 600 cd peak intensity at 7 W power
- Flasher with free programmable character
- Programmable Intensity
- Daylight sensor (lux)
- Accurate integrated power measurement system
- Wireless Bluetooth™ programming

Optional features

- Dated Shut-down
- GSM LTE-M LightGuard Remote Monitoring
- GPS Synchronisation
- GPS Position Check-up
- Event-log

2 Technical details

2.1 Optical Performance

The luminous intensity is adjustable between full intensity (400-600cd) and minimum intensity (4-6 cd). The effective visual range is from 2 to 8 nautical miles depending on light color and flash character. The maximum luminous intensity and power consumption for the two different lenses are listed in the tables below:

Wide Lens 10° FWHM (± 10%)	Nominal Luminous Intensity and Power Consumption (± 10%)
Color	
Green	600 cd @ 9W
Red	400 cd @ 7W
White	600 cd @ 9W
Yellow	400 cd @ 9W

(FWHM = Full Width, Half Maximum)

The actual visual range of the lantern is depending on the effective intensity, flash length and intensity setting of lantern. The effective intensity and hence the range of a single flash character is calculated in accordance to the IALA recommendation R0204.

In the lantern configuration device (Sabik Control Bluetooth App), the effective intensity is automatically calculated and displayed depending on settings selected by user. The base for this calculation is the luminous intensity stored in the lantern at the factory test at Sabik's in-house photometric range.

The main optical specifications are listed in the table below:

Specification	Value
Lens vertical divergence	10° Full Width at half maximum
Production tolerances of divergence	-1° + 2°
Lens material	UV stabilized polycarbonate
Light colours	Red/Green/Yellow/White in accordance with IALA recommendation

2.2 Energy Consumption

The lantern is designed for primary battery use and maintains a high overall efficiency over a wide range of supply voltages. Daytime idle consumption and consumption between flashes is minimized.

Specification	Value
Standard configuration	
Input voltage range	8...32 VDC
Max power consumption	7 – 9 W at full intensity (depending on LED color)
Daytime idle consumption	0.5 mA @ 12 VDC
Consumption between flashes	1.0 mA @ 12 VDC
Options	
GPS module installed	Average ≈1 mA @ 12 VDC
GSM module installed	Average ≈1 mA @ 12 VDC
Tilt angle monitoring	0.35 mA @ 12 VDC

The lantern intensity and hence power consumption can be adjusted between 1% and 100% depending on range required. The overall daily power consumption is depending on duty cycle of character, intensity setting and setting of daylight sensor (when to turn on/off).

When calculating the daily power consumption also the consumption between flashes and the consumption of any of the options installed should be considered.

Example of daily power consumption, no options:

Q: A RED MPV2 lantern set to 50% intensity and FI 3s (0.3+2.7=3s), 14 hours operation

A: Daily consumption = 50% x 7W x (0.3/3s) x 14h +
 (1-0.3/3s) x 0.012W x 14h + 0.006W x 10h = 4.9 Wh + 0.1512 Wh + 0.06 Wh = 5.1Wh

Total daily (24h) consumption = 5.1Wh

2.3 Mechanical

The MPV2 lantern is designed to be integrated on the top of an ice buoy, therefore requiring a special design of the top part of the buoy. The lantern can be installed on both plastic and steel buoys, but because of the heavy weight of the lantern, the buoy needs to be rather stable in order to be able to carry this load on the top.

The lantern is designed in two parts that may be hinged together, making it possible to install a primary battery through the centre hole of the lantern. In some applications, the lower flange may be omitted if there is no need to open the lantern for periodic replacement (like battery replacement).

Specification	Value
Weight of unit	24,6 kg
Base material	Bronze alloy resistance to marine environment
Total height above surface	141 mm
Lantern diameter	300 mm (331 mm including hinge)
Mounting of lower flange (base)	6 pcs M20 bolts at radius 240mm (bolts not included)
Fixing of upper flange to base	6 pcs M12 bolts at radius 258mm (included)

The lantern is fully waterproof and pressure tested at factory before shipment. Breathing is arranged through a PTFE membrane mounted on the underside of the lantern, enabling the lantern to equalize pressure without the risk of letting the moisture into the lantern.

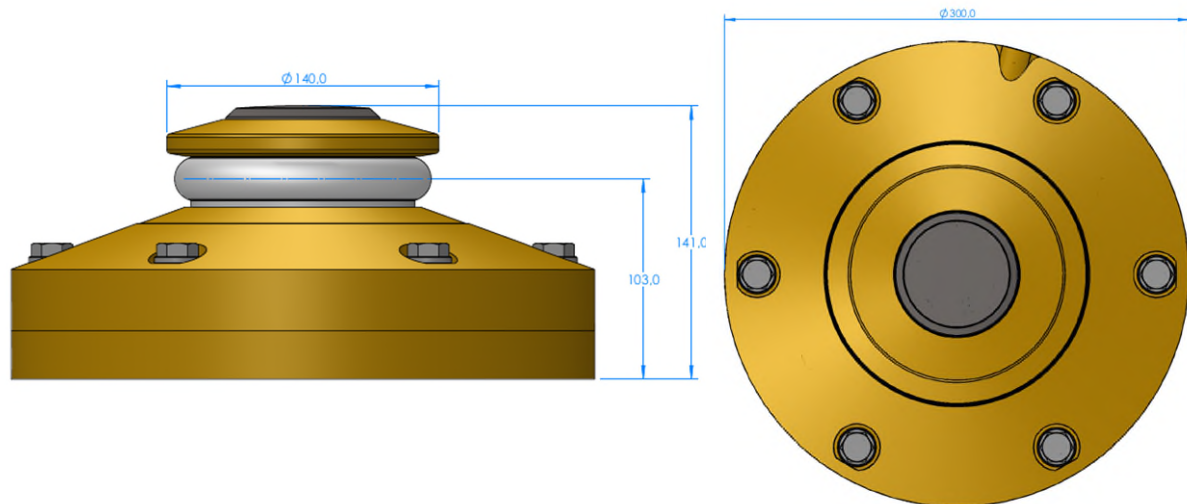

Figure 1- General Dimensions of the lantern

2.4 Electrical

The MPV2 buoy lantern is mainly operated on ice steel buoys and plastic ice spars where a primary battery option is the only power system available. In section 4.2 the connection of various type of power supplies are explained.

2.5 Light Sensor

The light sensor is located inside the optical lens, and located in the direction of the hinge of the lantern.

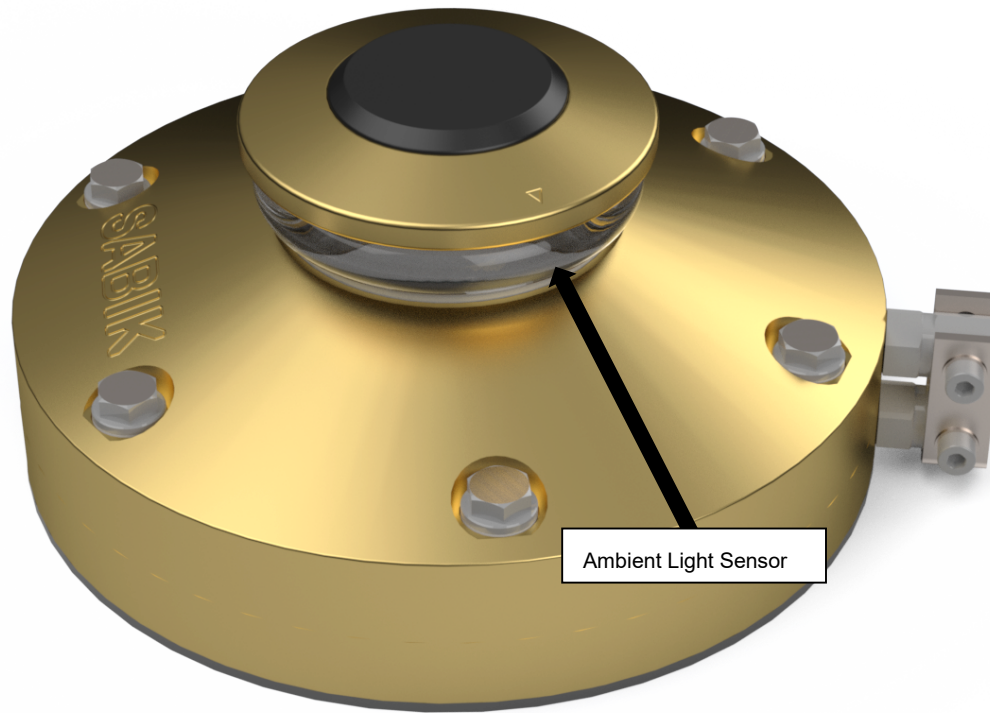

The light sensor measures ambient luminance level (lux). It is calibrated for twilight and limited to 250 lux. The factory default setting is to switch on the light at 15 lux and off at 60 lux. The built-in light sensor can be utilized even if the lantern is set to steady burning light, as it is able to get a reading between two light pulses (the LED's are powered using pulse width modulation). However, if the full 100% intensity is required, the lantern will automatically reduce this by about 5% in order to enable the light sensor to get a reading between the PWM pulses.

2.6 EMC

The lantern is tested for EMC in accordance with EU Directive 2014/30/EU Electromagnetic Compatibility Directive, and meets the following test standards:

- IEC 61000-4-2/7.1
- IEC 61000-4-3
- IEC 61000-4-4/7.2
- IEC 61000-4-5/7.8
- IEC 61000-4-6/7.2
- IEC 61000-4-11/7

NOTE! On plastic buoys special care should be taken to ground the top of the buoy in order to prevent a high electrostatic charge to build up over time. By adding grounding connection from lantern mounting to the submerged part of the buoy this can be prevented.

2.7 Environmental

The lantern is designed for heavy ice conditions and is able to withstand both the static ice pressure and the dynamic forces present when ice is moving. It may be submerged for periods of up to weeks when the buoy is pressed under the ice.

Specification	Value
Temperature range	-40°C to +60°C ambient temperature
Ingress protection	Equivalent to IP68 (1 meter submersion)
Maximum Ice Force	65 kN

The lantern design has been proven in field as well as tested with forces up to 65 kN.



© Solar Simulator

3 Optional Modules

3.1 Dated shut-down

The dated shut-down feature is a software dependent option, which can be enabled with the Sabik Bluetooth™ Control App. By setting a shut-down date and a start-up date in the controller, the lantern can be switched off to save power during times when channels/fairways are closed.

3.2 LTE-M LightGuard Monitoring

With the LightGuard module Remote Monitoring features are integrated in the lantern. The LightGuard Module uses the GSM Network to send Status messages to the Sabik LightGuard Monitor system. A subscription is required.



The following key monitoring features are available:

- **Alarm and Status reporting** – The LightGuard Module can be setup to report on Day/Night change and at a certain time intervals. The reports are sent automatically to the LightGuard system and includes the important lantern health information e.g. battery voltage, power consumption, error status, temperature, operating hours, daylight-sensor status.
In case of a fail: low battery voltage, light failure etc. the LightGuard module will report immediately.
- **Out of Position Alarm** – LightGuard will monitor its position and send a report if the buoy moves outside the programmed geofence. A high accuracy GNSS module with advanced averaging algorithm is used to maximize the position accuracy. A typical position accuracy is about +/- 3 meter.
- **Synchronizing** – the light can be synchronized with other lights equipped with same option.

3.3 GPS synchronization only

The GPS synchronization feature is an additional hardware and a software dependent option. By adding the GPS module and enabling the synchronization with the Sabik Bluetooth™ Control App, lanterns can be synchronized via satellite. By altering the synchronization offset, a running light or sequential light pattern can be created. If LightGuard remote monitoring option is installed, the GPS will also be utilized for the position monitoring.

3.4 Event-log

The lantern store main events which can be retrieved by service technician using the Sabik Bluetooth™ App. All day / night transitions as well as any alarms will be stored in the lantern, and is available to download using Bluetooth™ at any point. The lantern has capacity for a minimum of one year of events. The data is stored in a non-volatile memory independent on external power supply.

4 Commissioning

This chapter describes how to install and configure the lantern.

4.1 Configure Light Colour

The lantern can emit three different colours and there are two colour combination models, Red-Green-White or Red-Green-Yellow. The exact model of the lantern can be read from the product code, RGW or RGY.

The light colour is set with the Bluetooth™ Control App. Instruction on the usage is described in more detail in section 4.4. It's possible to lock the light color with DIP switches located underneath the venting plug.

NOTE! If the light colour is selected with the DIP switches (only one colour ENABLED), it's not possible to configure the light colour using the Bluetooth™ App.



4.2 Various Power Supplies

In this section, a number of application examples are provided to assist choosing the right configuration.

4.2.1 Primary Battery

Even though the minimum operating voltage of the lantern is 8V, it should not be connected to a primary battery with a nominal voltage of less than 12V to allow for voltage drop when cells being discharged.

If the primary battery used does not have an internal fuse an external one must be included in the system.

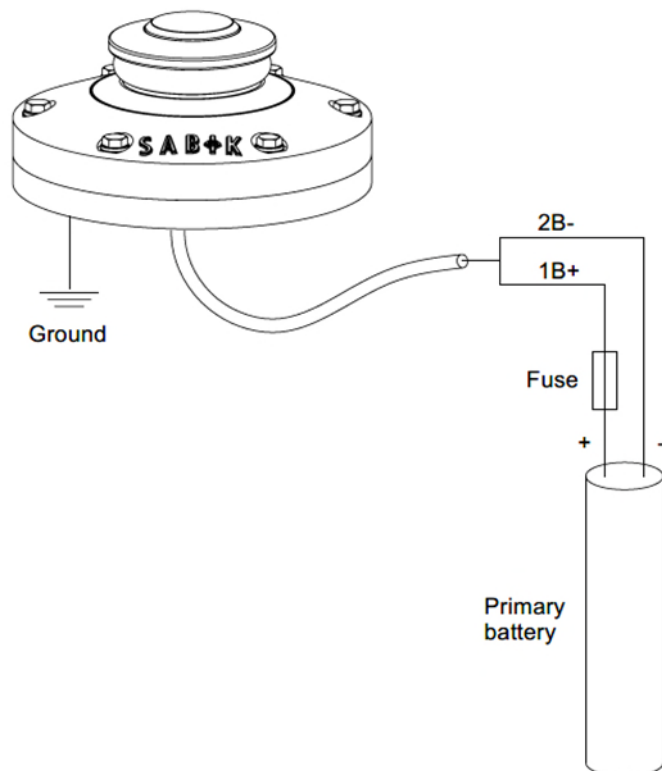

4.2.2 Other DC Power Supply

When using AC/DC main operated power supplies, special attention should be paid to make sure that the power supply selected is capable of powering the unit. Especially the ripple, the transient current capability and inductance should be checked against the requirement of the lantern.

4.3 Insert SIM Card (Only lanterns with GSM Module)

The lantern uses 4FF SIM Card size (Nano SIM) which will be provided by Sabik. Third party SIM's will not work properly with the lantern.



Figure 2 – Swipe left to unlock and lift up the SIM card holder and place SIM card in the holder



Figure 2 – Close the SIM card lock and slide it to the right in order to secure the SIM card

4.4 Programming

The lantern is equipped with Bluetooth as standard. A legacy infrared port is provided underneath the venting plug. The infrared port is compatible with Sabik easyProgrammer.

Bluetooth Control App

The Product is designed for programming and controlling Sabik Bluetooth® enabled lanterns using a simple user-friendly interface. The Android or iPhone app can be downloaded and installed to Bluetooth® 4.0 (Bluetooth® Smart) capable smart phone. The useable range between lantern and phone is usually more than 10m (the range is depending on type of lantern) and maximum up to 50m.

The energy consumption of the Bluetooth® chip is very low. These instructions are for Android devices but the instructions for iPhone are very similar.

Standard Features and requirements



The lantern settings can be read to your phone for monitoring purposes. If you have the access rights you also can make changes and send them to the lantern. You cannot store the settings on your phone.

The app requires a minimum of iPhone 4s or a Bluetooth® 4.0 (Bluetooth® Smart) capable Android phone with operating system 4.3 or higher.

Installation

The app can be downloaded from Apple (<http://store.apple.com>) or Google (<https://play.google.com>) for free. Observe, that you may have to register yourself before downloading. The app is free of charge.

Installation

Follow the instructions on Google or Apple Store

Registration

For the application to be able to work, you have to register your application using a valid user name and a password. Please contact your dealer to obtain these. This procedure has only to be done once.

Launching the application

After the installation, you should find an icon for the Bluetooth® app. You may relocate it if necessary.

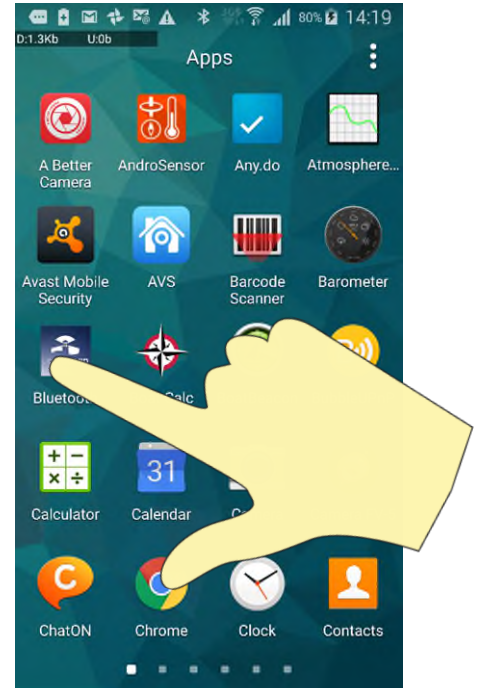

Login and selecting lantern

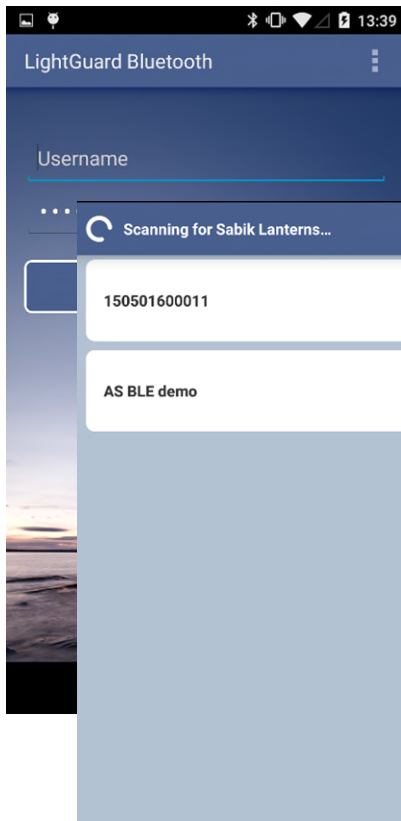

Fill in your user name and password and tap “Login”.

-if you don't have a user name and password, please contact your dealer to obtain these.

This information is stored in your device so the next time you will be logged in just by tapping the “Login” button

Now the app will search for Sabik lanterns within Bluetooth® range and display them in a list. Any lantern which is connected to another user will not be shown in the list. The lantern serial number is the default Bluetooth® name. This name can be changed using the application. This default serial number is also printed on the lantern. Tap on the name to select it.

User interface

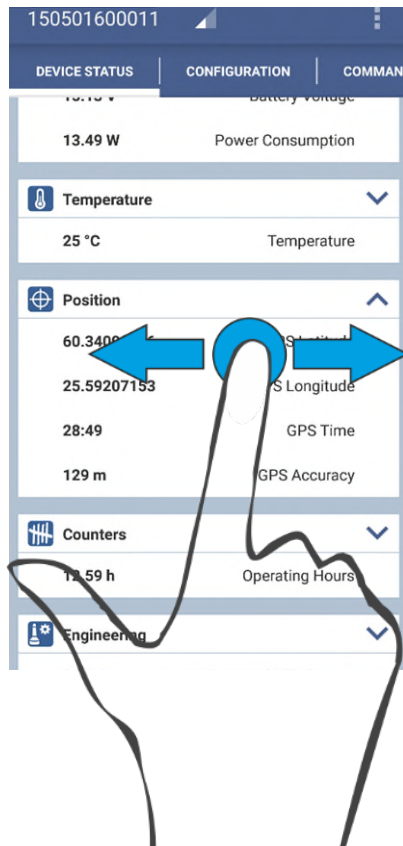

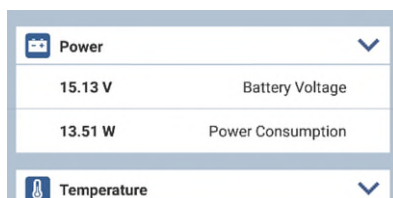

The interface labels are loaded from the lantern, so only the parameters relevant to this lantern are displayed. For instance, if there is no GPS function in the lantern, none are displayed in the application. The pages shows the standard settings.

The user interface is divided into screens. (DEVICE STATUS, CONFIGURATION, COMMANDS and ABOUT) To select a screen, swipe the screen to the right or left or tap a screen tab.

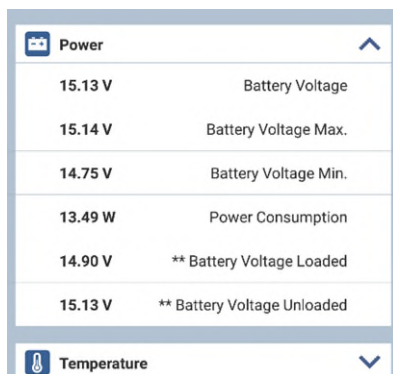

The Screens are divided into expandable blocks (Light, Power, Temperature etc.).For advanced settings, you have to expand the blocks. To expand a block just tap the  symbol near the right edge



Expanded view for advanced settings. Tap the  symbol to collapse.

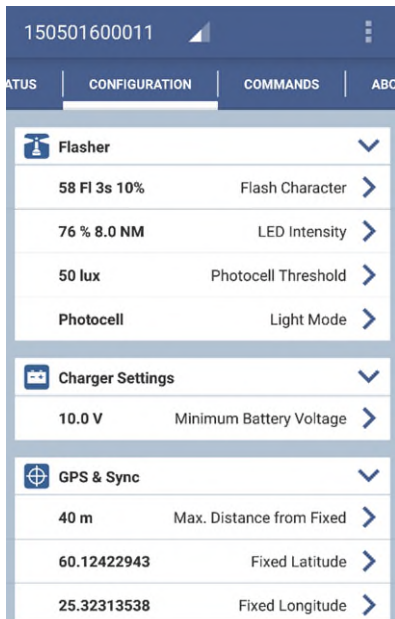

On the **CONFIGURATION** page, you can change the lanterns configuration by tapping the small >-shaped symbol on the right side of the setting's name. If needed, expand the block to see the advanced settings.

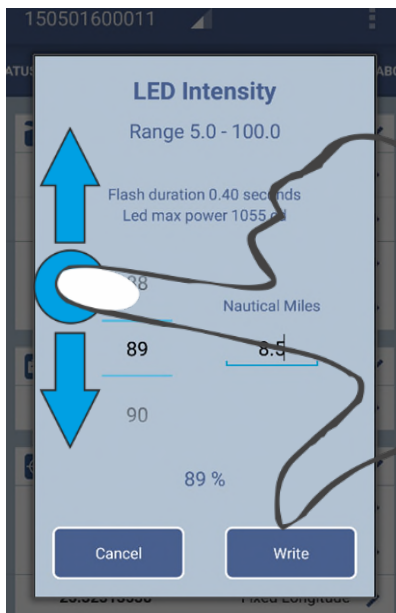

When, for example, LED Intensity is selected, you will be able to adjust the intensity by writing the range (in NM) or adjusting the intensity in percent. You can write the percentage or select it by swiping the numbers up or down.

Tap Cancel to cancel or Write to send the updated value to lantern. The edited parameter is immediately stored in the lantern and the new value flashes briefly after it has verified by the lantern.

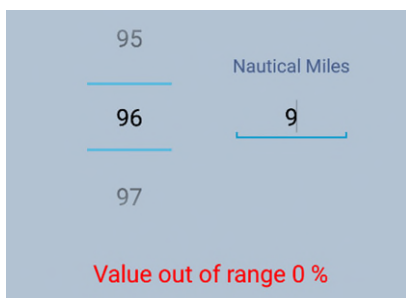

If the set value is too high or low, a warning message is shown and the value cannot be stored.

Pages

On the pages you will find information about the lantern, change settings and send commands. Observe that if your lantern do not have a specific module installed, then there is no information about that module.

DEVICE STATUS

Here you will find information about the Light, Power, Temperature, Position, Counters and Engineering values. You cannot make any changes to the lantern from this page. Observe, that some values/settings may not be available in your lantern.

Light

Light Status:	Shows the current light status, Active/Idle
Lantern Health Status:	Any possible error or warning is shown in the health status
Photocell Value:	Shows the real-time photocell value
Day-to-Night:	Latest transition time from day mode to night mode
Night-to-Day:	Latest transition time from night mode to day mode

Power

Battery Voltage	Real time battery voltage
Battery Voltage Max	Maximum battery voltage during the last 24h
Battery Voltage Min	Minimum battery voltage during the last 24h
Battery Voltage Avg	Average battery voltage during the last 24h
Power Consumption:	Real time power consumption (measured only when light is lit)

Temperature

Temperature	Real time temperature
Max. Temp. 24h	Maximum temperature during the last 24h
Min. Temp. 24h	Minimum temperature during the last 24h
Avg. Temp 24h	Average temperature during the last 24h

Position (If GPS module installed)

GPS Latitude	Latest measured latitude position
GPS Longitude	Latest measured longitude position
GPS Time	Time of last fix
GPS Accuracy	GPS horizontal dilution of precision

Counters

Operating Hours	Total illumination time
Power Cycle Counter:	Indicates the number of times power has been removed from lantern
System Reset Counter:	Number of reboots

Engineering

Measured LED Current
Measured LED Voltage
Lantern Tilt Angle
LED Max Intensity

CONFIGURATION

On this page you can review and change the values of the Flasher, Charger, GPS & Sync, Tilt and Impact, Dated Shutdown and Bluetooth® Settings. Tap Write button to send new values to the lantern. The advanced settings are shown in *italics*

Flasher

Flash Character:	Select a standard flash character or create a custom flash character.
LED Intensity:	Change LED Intensity based on intensity percent value or distance (NM)
Photocell Threshold:	Lantern operating ambient light threshold in lux
Light Mode:	Lantern operating mode (Photocell, Forced Idle, Forced Active or Day Lantern)
<i>Advanced Settings</i>	
<i>LED Current:</i>	<i>Product specific setting that must not be changed!</i>
<i>Photocell Hysteresis:</i>	<i>Hysteresis setting for turning off the lantern (lux)</i>
<i>Astro Offset Sunrise:</i>	<i>Offset for turning lantern off when in Astro mode (min)</i>
<i>Astro Offset Sunset:</i>	<i>Offset for turning lantern on when in Astro mode (min)</i>
<i>Lantern Type:</i>	<i>Lantern Installation Type (Stand alone, Primary or Standby)</i>
<i>Event log:</i>	<i>Enable (Yes) or disable (No) the Event log</i>

Charger Settings

Minimum Battery Voltage:	Minimum Voltage level for light operation.
<i>Advanced Settings</i>	
<i>Cut In Voltage:</i>	<i>Set minimum voltage for start charging.</i>
<i>Cut Out Voltage:</i>	<i>Set voltage for charger to stop charging.</i>
<i>Charging Mode:</i>	<i>Set charging mode (On/Off or PWM charging)</i>
<i>Battery Hysteresis:</i>	<i>Battery reconnecting hysteresis (V)</i>
<i>Battery Temp. Compensation:</i>	<i>Charging temperature compensation (-mV/°C)</i>
<i>Boost Charge Hysteresis:</i>	<i>Set boost charge compensation (V)</i>

GPS & Sync

Max Distance from fixed:	Max drift distance from GPS fix (meters)
Fixed Latitude:	Set fix Latitude
Fixed Longitude:	Set fix Longitude
GPS Check-up Interval:	Set position check-up interval (min).
GPS Check-up Duration:	Set position check-up duration (min)
Sync Setting:	Set lantern Sync mode (Off, Cable, GPS or Cable and GPS)
<i>Advanced Setting</i>	
<i>Sync Delay:</i>	<i>Set Sync Delay (sec)</i>

Tilt and Impact

Tilt angle Limit: Set maximum allowed tilt angle (deg) before shutdown occurs.
Advanced Setting
Shutdown if tilted: Set lantern to shut down if tilted (Yes or No)

Dated Shutdown

Dated Shutdown Enabled: Enable or disable dated shut down (Yes or No)

Advanced Settings

Shutdown Date: Set date to shut down lantern
Startup Date: Set date to start up lantern

Bluetooth Settings

Bluetooth Device name: Set lantern's Bluetooth name

Advanced settings

PIN Code Enabled: Enable or disable lantern PIN code (give PIN code to change setting)
PIN Code: Set new PIN Code

COMMANDS

On the COMMANDS page you can do a lantern test and download the event log.

Test Lantern

The Test command runs the lantern for 3 minutes.

Download event log

This command will download the full event log to your phone. You can now save it or share it.

Create a custom Flash Character; Step by Step Instructions

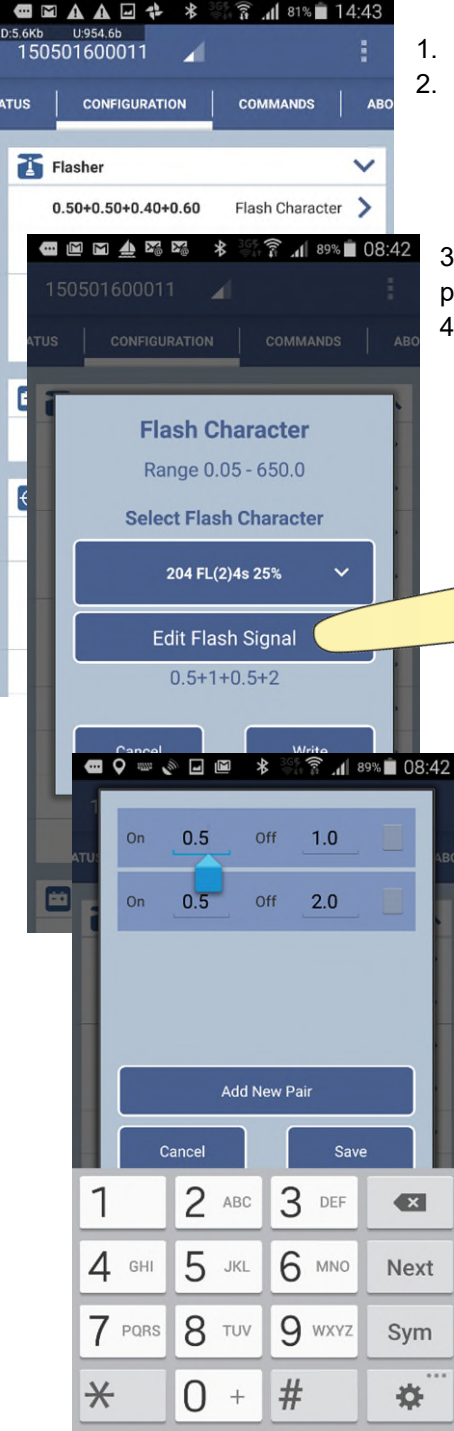

1. Select CONFIGURATION page
2. Tap on > symbol to the right of Flash Character
3. Select an existing Character from the list as a starting point and
4. Tap "Edit Flash Signal" to customize the character.
5. Change the On/Off timing. If needed add a new On/Off Pair or delete an existing pair by tapping the gray X. Tap Save, when done.
6. The new character will be saved as Custom.

5 Periodic Maintenance

The MPV2 is a robust lantern designed to withstand heavy abuse and requires no maintenance, except for battery replacement and lens cleaning. To maintain a good light output and achieve a long service life, it is advisable to inspect the lantern whenever visiting the buoy.

Mechanical inspection and maintenance:

- Check the lantern for leakage and replace gaskets if necessary
- Clean the metal parts on the lantern
- Check the lens and clean it with a damp cloth (Do NOT use any solvents!)
- Check the mounting bolts and the plastic washers for damage and replace if necessary.

Functional inspection and maintenance:

- Check that the lantern turn on by covering the lens
- Check that the LEDs have equal intensity
- Check that the lantern turn off by removing the cover (there is an about 30s time hysteresis)
- Read status values using the Sabik Bluetooth™ App.
- Check battery voltage with the App. If battery voltage is low, replace the battery

6 Troubleshooting

Q: There is water or moist inside the buoy. Where is the leakage?

A1: The bolts are loose or nylon washers damaged. Tighten the bolts. (Do NOT over tighten!)

A2: Open the lantern and check for damage on the O-ring and surface. Replace the O-ring if there are signs of damage.

A3: Remove the lantern including the flange from the buoy and check for damage on the gasket and the surfaces that are between the buoy and the flange. Replace the gasket if there are signs of damage.

A4: Check the PTFE membrane and replace if necessary.

Q: I covered the lens, but the lantern does not turn on.

A1: Read controller values with the App and check status. The battery voltage is below the minimum programmed value. Replace the battery.

A2: Read controller values with the App and check status. There is a lamp failure error. Return the lantern for service.

A3: Read controller values with the App and check status. The day light sensor value is... Return the lantern for service.

A4: The dated shut-down feature may be enabled.

Q: I covered the lens, but the lantern does not turn on and I cannot find the lantern in the Sabik Control App.

A: Check the battery cables for damage or short-circuit. Replace the battery.

Q: I covered the lens, but the lantern does not turn on and I cannot read controller values with the App even though I replaced the battery.

A: Return the lantern for service.

7 Appendixes

7.1 Explosion view

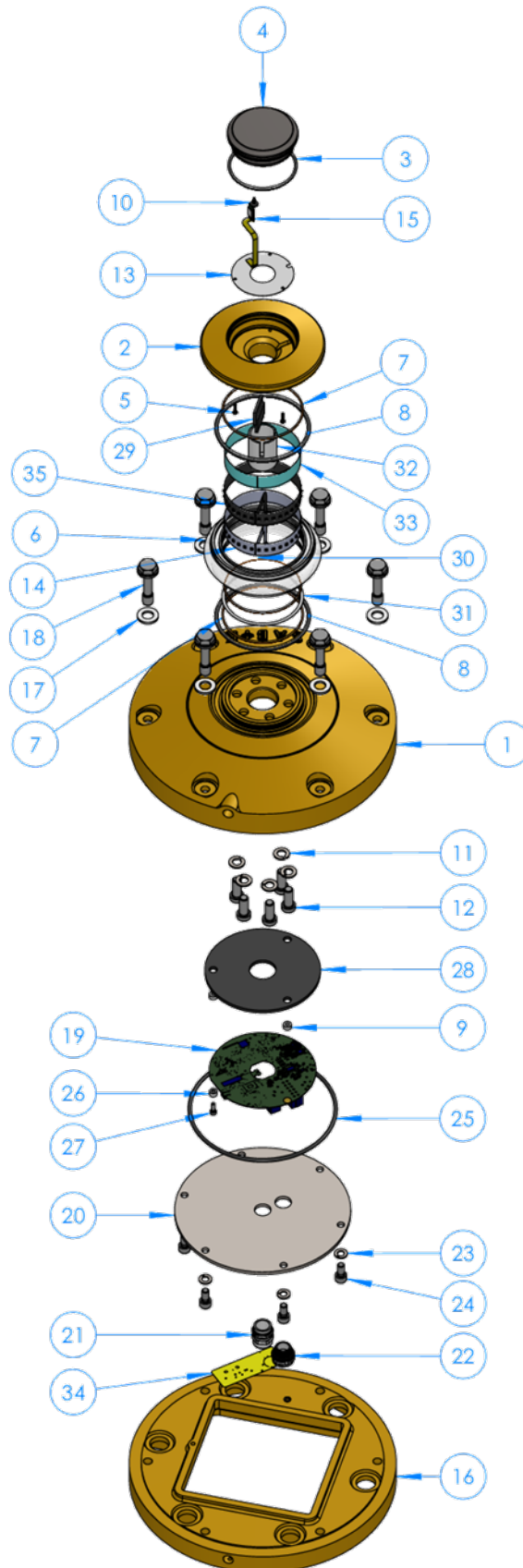

7.2 Part List

Part	Document Number	Sabik code	Title	Material	Manufacturer	Manufacturer PN	Revision	Qty
1	M131580		MPV2 Flange	RG7			B	1
2	M131574		MPV2 Hat	RG7			A	1
3	M133373		O-ring 72,0x3	EPDM	Tisan	03594		1
4	M132501		MPV2 Hat plug basic	Polyasetal			A	1
5	M100431		Torx screw 3x12 WN1452	A2	Wurth elektronik	WM1402312	0	3
6	M131581		MPV2 Lens	PC			0	1
7	M133374		O-ring 88,0x2	FPM	Tisan	09830	0	2
8	M131586		O-ring 100x4 EPDM	EPDM	Tisan	10007		2
9	M132443		Round unthreaded spacer 4,8mm	PVC	Essentra	SS8-4.8MML	-	3
10	M132447		Push fastener Nylon	Nylon	Essentra	468811		1
11	M100170	634400	Spring lock washer M10 DIN127	A4			-	6
12	M100249	619302	Hexagon socket head cap screw M10x25 DIN7984	A4			-	6
13	M132450		MPV2 GPS Insulation sheet	Omay U42B			A	1
14	M132453		MPV2 led card (RGW)					1
15	M132454		BTMPV2-F/BTMPV2-T					1
16	M000072		MPVLED Lower flange				A	1
17	M100629	634827	Washer M12	Nylon			-	6
18	M100630	892677	MPV LED Bolt M12	A4			-	6
19	M132530		SMCMPV2					1
20	M132528		MPV2 Cover plate	A4			0	1
21	M100066	591100	Cable gland M20x1,5	NIMS			-	1
22	M133436		Venting system M20x1,5 (TL10)	Polyamide 66	Bimed	SBVPE-11-WN (TL10)	-	1
23	M100132	634395	Spring lock washer M8 DIN127 A4	A4			-	6
24	M100171	619287	Hexagon socket head cap screw M8x16 DIN912	A4			-	6
25	M100077	651384	O-ring 160x4	FPM			0	1
26	M132543		Insulating cup washer	Nylon	Essentra	16CW008043		2
27	M100291		Hexagon socket head cap screw M4x12 DIN912	A4			-	3
28	M132549		MPV2 SMC insulation sheet	Sotukumi POR 303/B 4,0mm	TT Gasket		0	1
29	M132552		MPV2 Card insulation	Sotukumi POR 303/B 3,0mm	TT Gasket		0	2
30	M132587		O-ring 84x2 FPM 80sh	FPM			0	1
31	M132590		MPV2 Led card insulation sheet	Omay U42B			A	1
32	M132550		MPV2 Insulation pipe	PVC			0	1
33	M132577		MPV2 Thermally conductive adhesive transfer tape		Elgood			1
34	M132790		SMC MPV 2.0 label, 80x30mm	3M 7983			0	1
35	M133420		MPV2 led card (RGY)					1
36	M100289	634301	Spring lock washer M4 DIN127	A4			-	1