

VRL-74 & VRL-91 LED MARINE RANGE LIGHT BEACONS

Version: 1.0.23
Date: December 17, 2020

Document revision history

Manual Revision	Date manual released	Description of Change	Soft ware version	PEL-4 Serial number
1.0.0		Initial Release	002	74-00000050 74-00000060 74-00000070 74-00000080
1.0.1		Red-specific; includes 2-optic through 6-optic models; voltage control features removed.	003	74-00000120 to 74-00000200
1.0.2		<ul style="list-style-type: none"> Added colors vs. number of optics performance tables for all colors to Appendix B. Added spreader correction factors and release status to Appendix B. Added Yellow beacon specs. Added Appendix E Fitting of Spreaders. Updated red current consumption in Appendix B. Updated current consumption for lowest settings for all colors in Appendix B.	003	74-00000210 to 7400000-240
1.0.3		Special build: Day & Night have differing optics active.	004	74-00000250 -
1.0.4		Added LED 462 for very low intensity special builds (white).	004	74-00000270 -
1.0.5		<ul style="list-style-type: none"> Generalized separate day/night control as separate optic-group control. Added spreader fitting/removal appendix.	004	74-00000370-
1.0.5		Improved sync functionality.	005	74-00000380-
1.0.6	2013/6/20	Added flash character table as Appendix E.	008	74-00000630-
1.0.7	2013/7/3	Added flash character 930.	009	74-00000640-
1.0.7.MH	2013/7/11	Revised for High/Low control input in place of light sensor.	009	74-00000640-770
1.0.8	2013/11/7	Merged 1.0.7 & 1.0.7MH & generalized features. Describes both Standard & Extended I/O units.	010+	74-00000920+
1.0.9	2014/1/9	<ul style="list-style-type: none"> Accounted for ambient temperature offset in higher-power units. Updated single optic GA.	012+	74-00000940+

Manual Revision	Date manual released	Description of Change	Software version	PEL-4 Serial number
1.0.10	2014/11/7	Updated spreader release list.	012+	74-00000940+
1.0.11	2014/12/10	Product Version 2.0	204+	74-00001480+
1.0.12	2015/3/17	Automatic current range and optic number change with programmed intensity	209+	74-00001750+
1.0.13	2015/3/26	Manual generalized for multiple colors and spreaders	209+	74-00001770+
1.0.14	2015/5/19	<ul style="list-style-type: none"> Added 3 degree optic tables Fixed low-intensity software calibration bug Upgrade controller to V1.5HW Limited lowest PWM duty cycle to 1% for driver stability. 	210+	74-00001860+
1.0.15	2015/6/23	Merged in VRL-91 manual.	210+	74-00001860+ 91-00000040+
1.0.16	2015/9/8	<ul style="list-style-type: none"> Added VRL-74 red & white spreaders Minor adjustments to performance tables	211+	74-00002120+ 91-00000040+
USCG 1.0.17	2015/9/9	<ul style="list-style-type: none"> Generated USCG-specific version. Added factory default reset command variants. Changed to international date format.	212+	
USCG 1.0.18	2015/10/22	<ul style="list-style-type: none"> Added GPS detected TVIR enquiry Removed description of Storage mode as not relevant to VRL-74	213+	74-00002200+ 91-00000050+
USCG 1.0.19	2015/10/28	<ul style="list-style-type: none"> Performance table reformatting. Minor edits and US spelling corrections. Added description of optic sight mounting option and changed 'iron sight' to 'fixed sight'.	213+	74-00002200+ 91-00000050+
USCG 1.0.20	2015/12/14	<ul style="list-style-type: none"> Updated spreader mounting instructions Updated special character table	213+	74-00002200+ 91-00000050+
USCG 1.0.21	20170515	Included Vega Platform Mount (VPM-2) drawings	213+	74-00002200+ 91-00000050+

Manual Revision	Date manual released	Description of Change	Software version	PEL-4 Serial number
1.0.22	2017/6/12	<ul style="list-style-type: none"> Corrected manual version typos in this table. Released sw version 225 with new LED configs in red, white & yellow. Improved open-circuit LED detection at low PWM duties. Corrected minimum intensity settings in VRL-91 tables. New base mounting details released. 6-up VRL-91 mounting platform (VPM-6) drawings included. Error logging functionality included in Appendix A. <p>Included error code & troubleshooting information.</p>	225+	74-00002950+ 91-00000210+
1.0.23	2019/3/30	Manual updated to include 24V operation as well as 12V.		

VRL-74 Serial Number: 74-00002950+ VRL-91 Serial Number: 91-00000210+	June 2017
Model Numbers	VRL-74 Mini-Arrays VRL-91
Product Version	2.00
Software version	225
Manual version	USCG 1.0.23
Status:	Released

VRL-74 LED Versions by color, release date and serial number

RED LED			
LED Version	Release Date	VRL-74 Serial Number	VRL-91 Serial Number
164	June 2012	74-00000120+	-
168	June 2017	74-00002950+	-
171	April 2011	-	91-00000010

GREEN LED			
LED Version	Release Date	VRL-74 Serial Number	VRL-91 Serial Number
263	March 2012	74-00000050+	-
271	June 2015	-	91-00000050

WHITE LED			
LED Version	Release Date	VRL-74 Serial Number	VRL-91 Serial Number
464	April 2012	74-00000110+	-
462	November 2012	74-00000330, 340	-
465	June 2017	74-00002950+	-
471	July 2011	-	91-00000020
473	June 2015	-	91-00000060

YELLOW LED			
LED Version	Release Date	VRL-74 Serial Number	VRL-91 Serial Number
362	October 2012	74-00000240	-
366	June 2017	74-00002950+	-

VEGA INDUSTRIES LIMITED

21 Heriot Drive, Porirua 5022, New Zealand

Tel: +64 4 238 0200; Fax: +64 4 237 4392

E-mail: sales@vega.co.nz

Web: <http://www.vega.co.nz>

Product Warranty

Vega warrants that all products supplied are free from labor and material defects, and will repair or replace (at its option) the whole or any part of the products found to be faulty. The standard warranty is valid for 12 months from the date of dispatch. Vega is not to be liable for any charge beyond the point of delivery, including installation, alignment or testing. To claim under warranty the product must be returned to the Vega factory in New Zealand at the user's expense.

Legal Notice

Information in this document is subject to change without notice. Vega Industries Ltd. makes no warranty of any kind with regards to this material, including but not limited to, the implied warranties of merchantability and fitness for purpose. Vega Industries Ltd. shall not be liable for errors contained herein or for incidental or consequential damages in connection with the use of this material. No part of this document may be photocopied, reproduced, or translated to another language without prior written consent of Vega Industries Ltd. The Vega logo is a registered trademark of Vega Industries Ltd. All other trademarks belong to their respective proprietors.

Contents

1.0 INTRODUCTION TO THE VRL-74 & VRL-91 LED MARINE BEACONS.....	4
1.1 VRL-74 OVERVIEW	4
1.2 VRL-91 OVERVIEW	4
1.3 PERFORMANCE AT A GLANCE	4
1.4 CONSTRUCTION.....	5
2.0 ELECTRICAL CONNECTION.....	5
2.1 POWER CONNECTION.....	5
2.2 HARDWIRE SYNC CONNECTION	5
2.3 GPS SYNCHRONIZATION OPTION.....	6
3.0 ASSEMBLY, MOUNTING AND ALIGNMENT.....	6
3.1 VRL-74 ASSEMBLY	6
3.2 VRL-91 ASSEMBLY.....	7
3.3 MOUNTING AND ALIGNMENT.....	9
4.0 PROGRAMMING.....	11
4.1 PROGRAMMING SYNTAX.....	12
4.2 VISUAL FEEDBACK WHEN USING THE TVIR PROGRAMMER.....	12
4.3 THE BEACON WILL NOT ENTER PROGRAMMING MODE	13
4.4 BECOMING FAMILIAR WITH THE PROGRAMMING SYNTAX AND FLASH FEEDBACK.....	13
4.5 DECIDING WHICH SETTINGS ARE REQUIRED	14
4.6 PROGRAMMING OR READING MULTIPLE SETTINGS.....	14
4.7 PROGRAMMING FEATURES	14
4.7.1 <i>Flash Character</i>	14
4.7.2 <i>Custom Flash Character</i>	15
4.7.3 <i>Day/Night Use of the Beacon</i>	15
4.7.4 <i>Intensity Settings</i>	15
4.7.5 <i>Synchronizing Options</i>	16
4.7.6 <i>Loss of Sync when in Slave Sync Mode</i>	16
4.7.7 <i>Operation Mode</i>	17
4.7.8 <i>Battery Thresholds</i>	17
4.7.9 <i>System Information</i>	18
5.0 ROUTINE MAINTENANCE	19
5.1 MAINTENANCE CLEANING.....	19
5.2 INSPECTION CHECK.....	19
USER NOTES	19
APPENDIX A VRL-74 AND VRL-91 PROGRAMMING TABLE	20
APPENDIX B INTENSITY SETTINGS AND CURRENTS	23
APPENDIX B.1 VRL-74 OPTICS	23
Appendix B.1.1 <i>VRL-74 GREEN Intensity Settings And Currents</i>	25
Appendix B.1.2 <i>VRL-74 WHITE Intensity Settings And Currents</i>	37
Appendix B.1.3 <i>VRL-74 RED Intensity Settings And Currents</i>	49
Appendix B.1.4 <i>VRL-74 YELLOW Intensity Settings And Currents</i>	61
APPENDIX B.2 VRL-91 OPTICS	73
Appendix B.2.1 <i>VRL-91 GREEN Intensity Settings And Currents</i>	73
Appendix B.2.2 <i>VRL-91 WHITE Intensity Settings And Currents</i>	75
Appendix B.2.3 <i>VRL-91 RED Intensity Settings And Currents</i>	76
APPENDIX C BEACON SPECIFICATIONS	77

APPENDIX C.1 VRL-74 BEACON SPECIFICATIONS77
APPENDIX C.2 VRL-91 BEACON SPECIFICATIONS77
APPENDIX C.3 COMMON BEACON SPECIFICATIONS77

1.0 Introduction to the VRL-74 & VRL-91 LED Marine Beacons

1.1 VRL-74 Overview

Each VRL-74 LED Beacon is supplied for a particular application, the design depending on the color, flash character, vertical and horizontal divergence, and range required for that application. As such the number of optics required and physical configuration of two beacons may vary even though the range may be the same for different applications. The details of the application for this VRL-74 beacon are provided on the cover of this manual.

The number of lenses required for any application is determined from the peak intensity of the flash character and the thermal constraints of the LEDs in the beacon design. Longer on period within a flash character and lower duty cycle will minimize the number of lenses required and consequently the cost of the beacon.

There are six basic configurations of VRL-74 mini arrays; units with one, two, three, four, five or six LED units (see Appendix D for outline drawings and dimensions). All units have integral controllers mounted to the base unit.

The Product Version 2.0 beacons operate from a nominal 12VDC or 24VDC supply. The peak currents and the off currents of the beacons are detailed inside this manual.

VRL-74 beacon installation involves mounting and alignment and the supply of power. Adjustment of beacon settings can optionally be made using a TVIR Remote-02 and as detailed in Appendix B.

1.2 VRL-91 Overview

Each VRL-91 LED Beacon is supplied for a particular application, the design depending on the color, flash character and range required for that application.

The number of lenses required for any application is determined from the peak intensity of the flash character and the thermal constraints of the LEDs in the beacon design. Longer on period within a flash character and lower duty cycle will minimize the number of lenses required and consequently the cost of the beacon. Refer to Appendix E for dimensional information.

The Product Version 2.0 beacons operate from a nominal 12VDC or 24VDC supply. The peak currents and the off currents of the beacons are detailed inside this manual.

VRL-91 beacon installation involves mounting and alignment and the supply of power. Adjustment of beacon settings can optionally be made using a TVIR Remote-02 and as detailed in Appendix B.

1.3 Performance at a Glance

The VRL-74 LED Beacon has the following general capabilities:

- Available colors are red, white, green, and yellow.
- Nominal range is dependent on the color, flash character, divergence requirement, and the number of lenses used.
- The VRL-74 primary lens has a vertical and horizontal divergence of 3° measured at the point of 50 percent of the peak intensity. Wider divergences of 6, 9, 15, etc. degrees horizontal are achieved by factory-fitting secondary spreader lenses.
- Modular design allowing the beacon to be configured for each particular application.

- Programmed with Vega TVIR programmer Remote-02
- A 12-year design life

The VRL-91 LED Beacon has the following general capabilities:

- Available colors are: red, white, green.
- Nominal range is dependent on the color, flash character, and the number of lenses used.
- The VRL-91 only has a primary lens with a vertical and horizontal divergence of 3° measured at the point of 50 percent of the peak intensity.
- Programmed with Vega TVIR programmer Remote-02
- A 12-year design life

1.4 Construction

The metal components of the VRL-74 and VRL-91 Beacons are made from machined marine grade aluminum or stainless steel. All aluminum components are anodized. The LED lenses are made from machined cast acrylic. Heat is dissipated through the heat sink that the LEDs are mounted on.

The VRL-74 and VRL-91 are sealed against dust and moisture to the level of IP-67 and if either light is to be used outside will be fitted with bird spikes to prevent birds nesting. The lenses are fully sealed. There is no breather vent.

2.0 Electrical Connection

2.1 Power Connection

The VRL-74 and VRL-91 beacons, Product Version 2.0, are designed to work from a nominal supply voltage of 12VDC or 24VDC. They should not be connected to any voltage over 30VDC.

If the supply is connected in reverse a beacon will not operate. However, the beacon will not be damaged as it is protected from reverse polarity.

Power connection details are shown below:

Wire Color	Function	Comment
Brown	Vin +	+10VDC to +30VDC
Blue	GND	
Green/Yellow	Sync	Available on standard units. If the optional dataport is fitted then this signal is available on the green wire of the dataport.

2.2 Hardwire Sync Connection

The Vega hardwire sync (green/yellow wire) operates as a positive to negative transition. The start of the flash character can be delayed between 0 and 9.9 seconds from this sync edge should it be desirable to have a different start time to other beacons connected to the synchronizing wire.

Other beacon manufacturers may not use a negative transition signal. Please contact Vega regarding the availability of a signal inverter module.

The VRL-74 and VRL-91 can be hard-wire synchronized with other Vega 12V products, such as the VSU-29 and the VLB-5, VLB-36, VLB-44, etc.

2.3 GPS Synchronization Option

Where fitted, the GPS option provides internal GPS-based synchronization for the VRL74 and VRL-91 beacons.

3.0 Assembly, Mounting and Alignment

3.1 VRL-74 Assembly

Assembly and mounting is identical for all units, regardless of the number of optics. Please see Appendix D for overall dimensions of the VRL-74 units.

The only assembly required for the VRL-74 is fitting the bird spikes. The bird spikes are mounted on brackets; these need to be attached to the frame of the VRL-74. The location of the bird spikes depends on the orientation of the beacon – the three possible mounting arrangements are shown below.

Note – if the iron sight is going to be used for alignment, do not fit the bird spikes until the beacon is mounted and aligned.

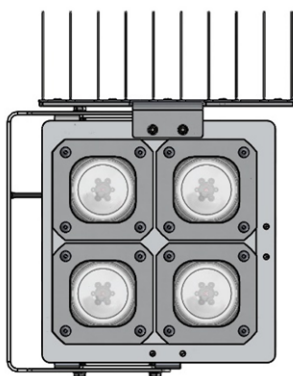

Vertical Mount – left side

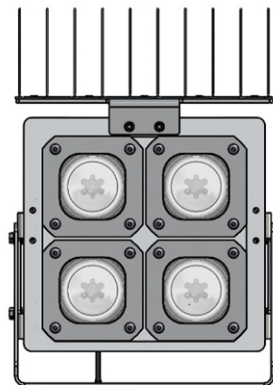

Horizontal Mount

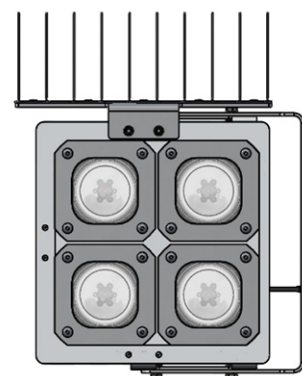

Vertical Mount – right side

Bird Spikes are installed with the hardware provided. The bird spikes should be installed so that they are pointing up, regardless of the mounting orientation of the light. Hold the bird spikes in place, aligning the holes in the bird spike bracket with the holes on the light (see figure for details). Install and tighten the socket head cap screws and plastic washers through the bird spike bracket into the light.

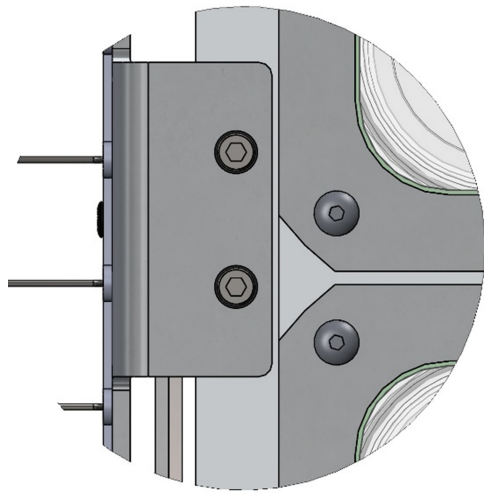

Vertical Mount – left side shown

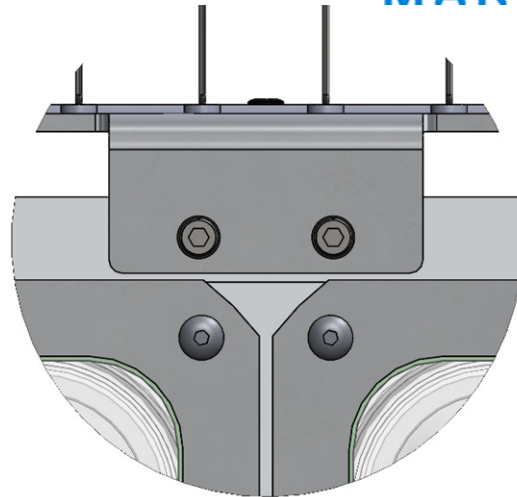

Horizontal Mount

3.2 VRL-91 Assembly

The only assembly required for the VRL-91 is fitting the bird spikes. The bird spikes are mounted on brackets; these need to be attached to the frame and hood of the VRL-91. The location of the bird spikes is shown in the following images.

Note – if the iron sight is going to be used for alignment, do not fit the bird spikes until the beacon is mounted and aligned.

Bird Spikes are installed with the hardware provided. The bird spikes should be installed so that they are pointing up. Hold the bird spikes in place, aligning the holes in the bird spike bracket with the holes on the light (see the red highlights in the following figure for details).

- To mount the bird spikes on the top of the heatsink, install the screws with metal washers through the bird spike bracket into the light and gently tighten.
- To mount the bird spikes on the top of the hood, feed a metal washer onto each screw, feed the screws through the bird spike plastic bracket and the hole in the metal hood. On the underside of the metal hood, place a plastic washer and Nylock nut onto the screw and gently tighten.

Please see Appendix E for overall dimensions of the VRL-91 units.

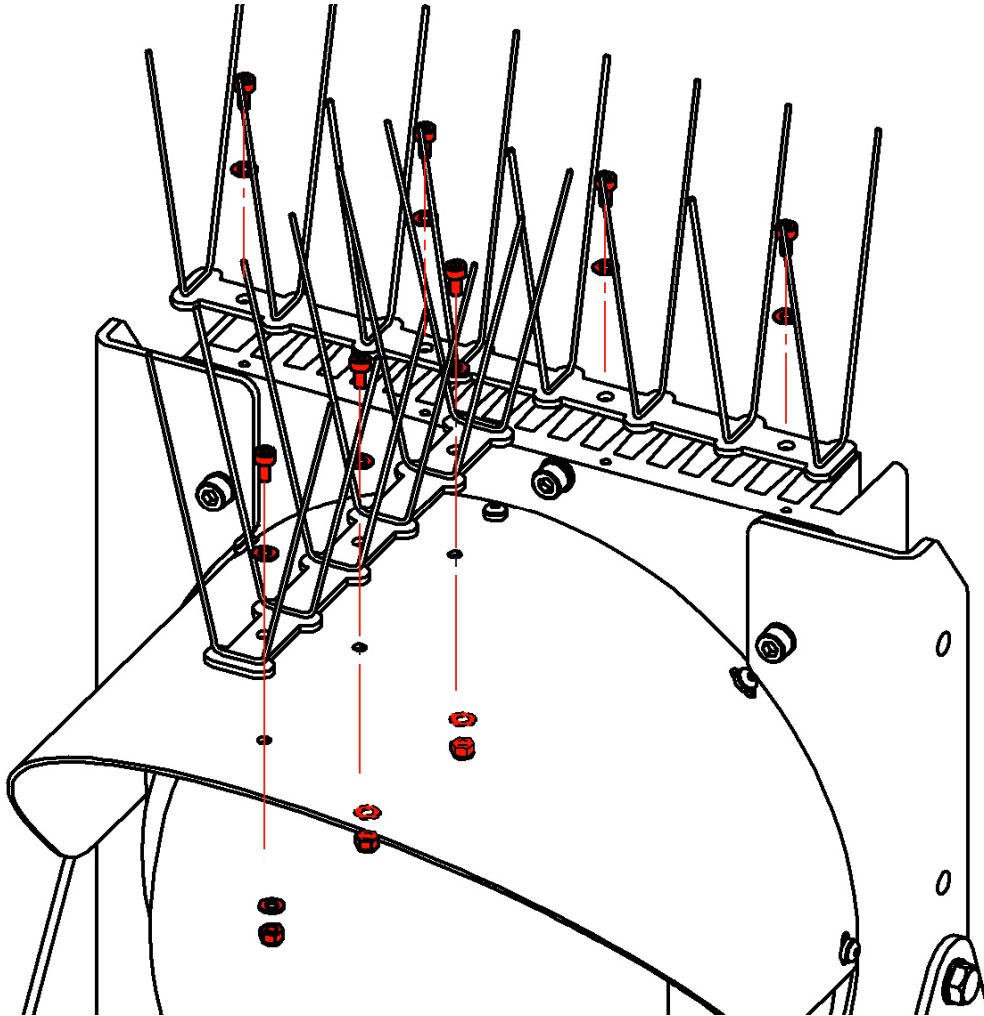

3.3 Mounting and Alignment

The VRL-74 and VRL-91 are mounted via up to five 13.5mm slotted holes on a 200mm Pitch Circle Diameter (PCD). The mounting holes are slotted to allow either beacon type to be adjusted in the horizontal plane by up to ± 6 degrees. The holes are arranged in two overlapping patterns of 90 degree and 120 degree spacing.

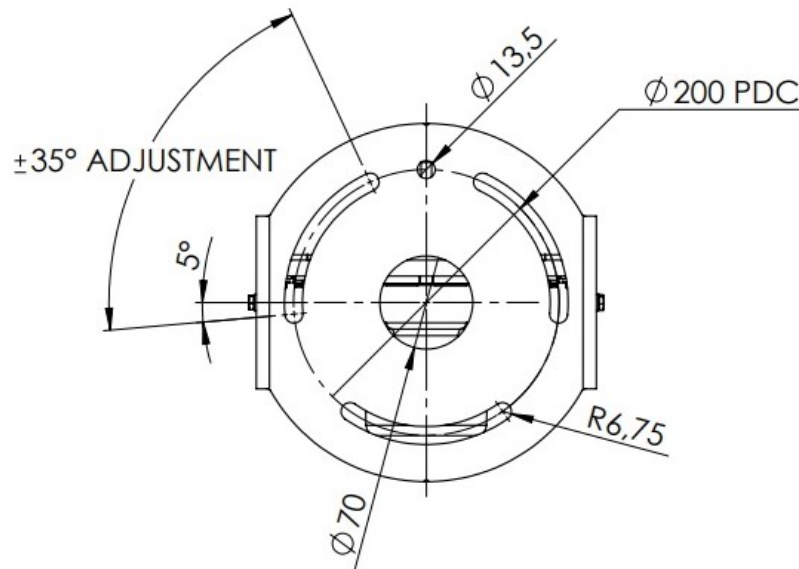

Underside view of beacon mounting

To align a beacon vertically, loosen off the four mounting bolts in the angle brackets and pivot the beacon about the top bolt (the bottom mounting hole is slotted).

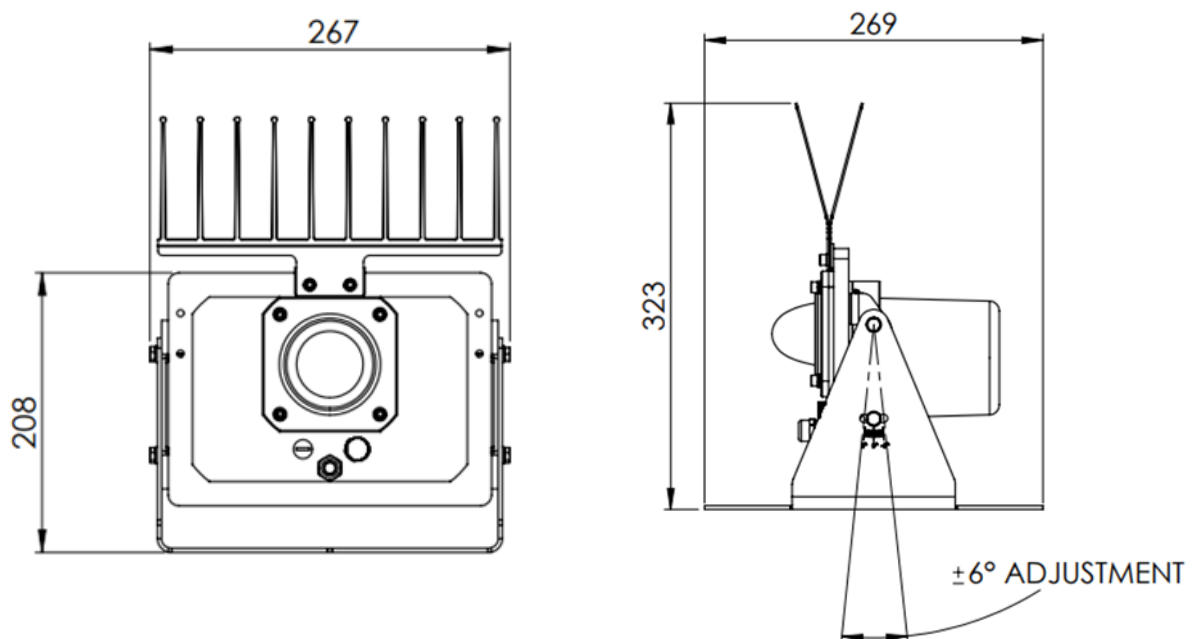

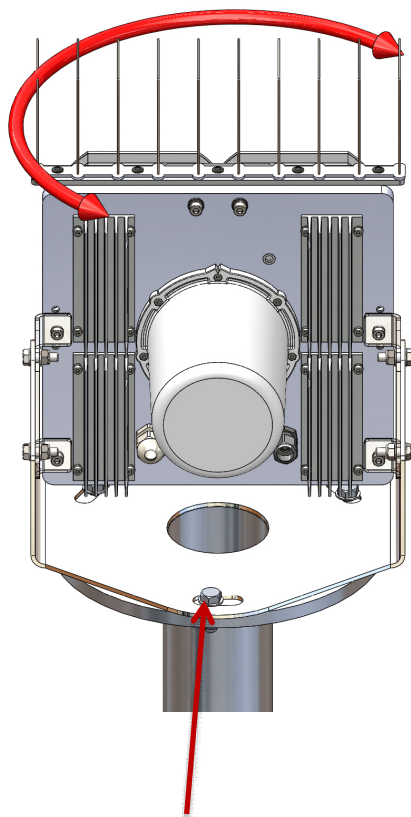

Horizontal alignment slot

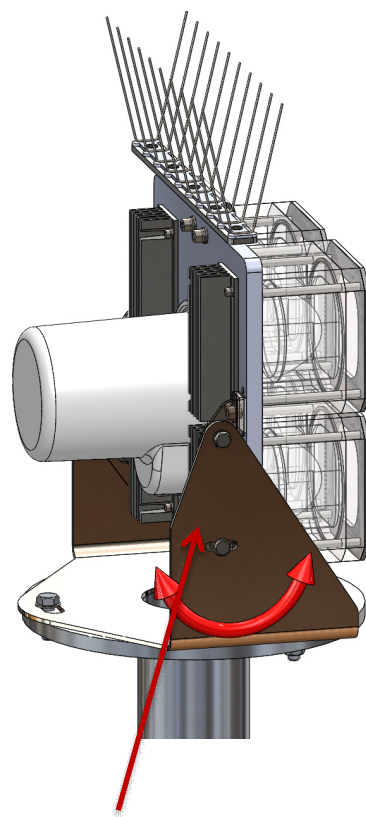

Vertical alignment slot

To aid with alignment a fixed sight unit can be ordered. (A 'fixed sight' is a sighting tool without optical magnification.) Remove the bird spikes (if fitted) and fix the iron sight to the top of the beacon's frame using the 2off M5x50mm cap screws supplied – as shown below. Ensure that the fixed sight's reference surface mates cleanly with the beacon's reference surface.

A scope mount is also available to allow the customer to fit an optical sighting scope with a standard Weaver mount. The scope mount fits to the VRL-74 in exactly the same way as the fixed sight does.

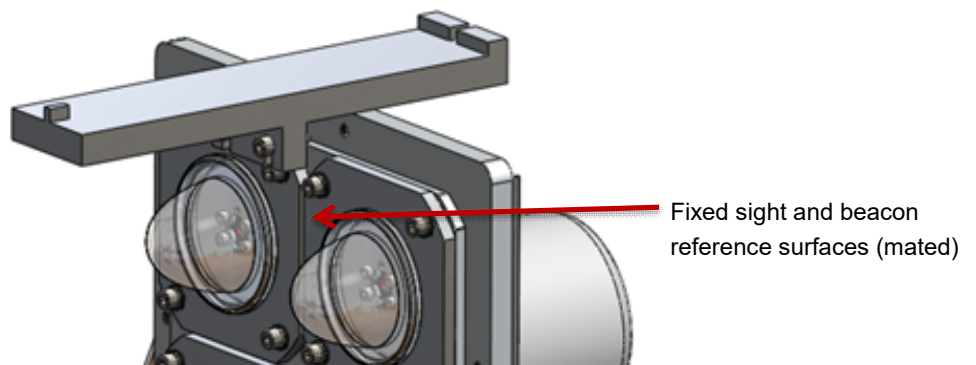

4.0 Programming

The VRL-74 and VRL-91 can be programmed using the Vega remote TVIR Programmer (Remote-02, shown below).

The infra-red sensor in the beacons is located inside the controller housing on the rear face of the unit (see picture below). Please locate the label “Aim TVIR Remote Here” on the rear cover of the beacon. The directions provided by this label may differ between VRL-74 and VRL-91 beacons. To program or read back settings the TVIR Remote-02 programmer needs to be pointed as directed by the label on the rear cover.

IMPORTANT
 Before attempting to use the Programmer for the first time, please pull the plastic insulating strip out of the battery holder – you do not need to remove the battery holder to do this.
 The programmer will not work if the plastic strip is left in place.

Red standby key, used to enter programming mode.

Numeric keypad, used to configure the programmable features of the light.



During programming the VRL-74 and VRL-91 will provide visual feedback by flashing the main LEDs and the red LED under the rear cover as the keys are operated on the TVIR programmer. On completion of a program option the beacon will provide visual feedback by repeating the code of the programmed function with a series of flashes.

4.1 Programming Syntax

Reading or writing parameters with the TVIR involves entering a sequence of numbers on the keypad. The programming syntax is: OPERATION FEATURE [VALUE]

Note: - the VALUE parameter is only required when writing data to the beacon.

There are four OPERATIONS available to the user:

Programming	Operation 1
System Information	Operation 3
Optional Special code	Operation 7
Read settings	Operation 9

The FEATURE parameter represents the feature of the beacon to be read or written such as flash character or intensity.

The VALUE parameter is the new value to set the selected FEATURE to.

For example, the sequence 9 8 reads the low battery threshold (operation 9 = read setting, feature 8 = low battery threshold).

Appendix A of this manual provides a Table for the programming features of the beacons. Please take the time to become familiar with the table before continuing.

4.2 Visual Feedback when Using the TVIR Programmer

The beacon will provide visual feedback of the programming instructions that it receives from the TVIR programmer. This feedback is provided to confirm that TVIR commands have been received correctly and therefore ensures that the beacon is programmed correctly.

The feedback is summarized below:

Programmer Keys	Light response
Enter Programming Mode (by pressing red standby key for 5 seconds)	4 quick flashes (0.1sec on 0.1sec off).
Numeric key when programming	1 flash for each key pressed
When programming sequence recognized	The 3 or 4 digit value code is output using a series of flashes of 0.1sec on and 0.1sec off with a gap of 0.5sec between each number of the code. A zero is represented by a 2 second on flash.
When programming sequence is not recognized	3 quick flashes (0.1sec on 0.1sec off) The beacon will remain in programming mode waiting for a new programming instruction.
Exiting Programming mode No programming activity for 10 Seconds	The light will give two quick flashes followed by a short pause followed by another two quick flashes. After this the beacon will resume normal operation.

4.3 The beacon will not enter Programming Mode

If you find the beacon will not enter the programming mode it will be caused by one of 2 reasons:

- The battery in the TVIR Programmer is missing, or the plastic battery insulator has not been removed, or the battery has low voltage.
- There is no 12VDC or 24VDC supply connected to the light.

If the beacon enters programming mode but rejects all commands that would change its settings then it requires a security PIN to be entered by the operator to allow programming. Refer section 4.8.9.

4.4 Becoming Familiar with the Programming Syntax and Flash Feedback

If you have not used the Vega TVIR Programmer before, spend some time learning how the light will respond to the various programming actions. Make sure the beacon is connected to a 12VDC or 24VDC supply and experiment with the following.

Enter and Exit Program mode:

<ol style="list-style-type: none"> 1. Enter program mode Press the red standby button for 5 seconds 	<p>The light will give 4 quick flashes to indicate it has entered programming mode</p>
<ol style="list-style-type: none"> 2. Exit program mode Leave the programmer idle for 10 seconds 	<p>The light will give two quick flashes followed by a short pause followed by another two quick flashes. After this the beacon will resume normal operation.</p>

Program the Flash Character:

Referring to Appendix A it can be seen that the flash character is feature 0. The three digit value that is read or written identifies a flash character from the table in Appendix F.

Operation	= Programming	= 1	
Feature	= Flash Character	= 0	
Value	= New Value	= 102	(i.e. ISO 4s)

The sequence to program this character is therefore 1 0 102

<ol style="list-style-type: none"> 1. Enter programming mode Press the red standby button for 5 seconds 	<p>The light will give 4 quick flashes to indicate it has entered programming mode</p>
<ol style="list-style-type: none"> 2. Enter the programming sequence for writing the flash character (1 0 102) 	<p>The light will flash once each time a key on the programmer is operated. When the sequence is completed and accepted the light will repeat the value 102 in a series of flashes. One quick flash followed by a 0.5sec gap followed by a 2 second flash (for zero) followed by a 0.5 second gap followed by two quick flashes</p>
<ol style="list-style-type: none"> 3. Exit programming mode Leave the programmer idle for 10 seconds 	<p>The light will give two quick flashes followed by a short pause followed by another two quick flashes. After this it will resume normal operation.</p>

After completing this exercise, be sure to set the flash character back to your desired value (the default is Q 1s 0.3s, code 601). All configuration settings are stored in EEPROM so cycling the battery power will not reset these values.

If an incorrect command is entered (e.g. for a non-existent flash character code) then the command will be rejected and an error indicated by 3 quick flashes.

Reading System Information

Referring to Appendix A it can be seen that the battery voltage can be read from the System Checks (feature 3), feature 1. The value that is returned is the battery voltage * 10 (three digits):

Operation = System Checks = 3
 Feature = Battery Voltage = 1

The sequence to read the battery voltage is therefore 3 1

1. Enter programming mode Press the red standby button for 5 seconds	The light will give 4 quick flashes to indicate it has entered programming mode
2. Enter the programming sequence for the information (31)	The light will flash once each time a key on the programmer is operated. When the sequence is completed and accepted the light will provide the voltage level in a series of flashes (12.3VDC). One quick flash followed by a 0.5sec gap followed by 2 quick flashes followed by a 0.5 second gap followed by three quick flashes.
3. Exit programming mode Leave the programmer idle for 10 seconds	The light will give two quick flashes followed by a short pause followed by another two quick flashes. After this the beacon will resume normal operation.

4.5 Deciding which Settings are required

As the beacon is delivered from the factory with default settings it is only necessary to program the settings that need to be changed. The “Read Settings” feature can be used to note the values already programmed.

4.6 Programming or Reading Multiple Settings

In the examples above the beacon was allowed to time out of programming mode after reading or writing each parameter. This is not necessary; multiple parameters can be read and written in one programming sequence.

4.7 Programming Features

Refer to Appendix A for the full list of programming features.

4.7.1 Flash Character

Vega beacons are pre-programmed with 246 standard characters, each represented by a three digit code (XYX). The first digit of the code represents a flash type – such as 1YY for Isophase characters. The second and third digits of the code select a specific flash character within the flash type defined by the first digit. The available flash characters can be found in Appendix F, grouped into flash types. Each flash character appearing in Appendix F has a unique three-digit code which can be programmed into the beacon by using the Program Flash Character operation.

If additional flash characters are required that are not included in the standard set, these can be included if advised at time of order. These would then be available for programming under Special character type 9YY and listed at the end of Appendix F.

Operation	=Program (or read)	=1 (or 9)
Feature	=Flash Character	=0
Value	=Select from Appendix A	=XYX

4.7.2 Custom Flash Character

To program the custom character the details of the on and off periods of the flash character must be recorded.

The programming a custom character has its own syntax and this needs to be followed correctly to be able to program the character successfully.

Operation	=Custom Character	=2
Value	=Code for the character	

The code is entered in a series of 3 digit values representing an on period or off period. Each 3-digit value is a multiple of 0.05 seconds. The 3-digit code for a 1 second on or off period would be 020 (20 multiplied by 0.05 seconds is 1 second).

The following restrictions apply:

- The minimum period that can be programmed is 0.1 second or the code of 002.
- The maximum period that can be programmed is 12.75 seconds or the code of 255. For longer periods than 12.75 seconds an ADD code can be entered

There are two special codes used as part of the custom character programming

- The ADD code to get on or off periods greater than 12.75 seconds = 001
- The termination code when the programming of the custom character is finished = 000

If an error occurs when entering a custom character the VRL-74 will flash the error code of 3 quick flashes.

Programming a custom character creates a flash character with code 999. To get the VRL-74 to use the custom character the value of 999 must be entered as the flash character.

4.7.3 Day/Night Use of the Beacon

The beacon can be configured to operate at night-only or at day and night.

The standard beacon with photocell day/night detection will transition from day to night mode and vice versa based on pre-programmed day and night Lux levels. The default day/night transition setting is 1-4-009, which sets the USCG longest night thresholds of 250 lux and 320 lux. A factory default reset returns the beacon to this day/night threshold setting.

Operation	=Program (or read)	= 1 (or 9)
Feature	=Day/Night Control	= 4
Value	=Select from Appendix A	=009

The first digit (0) of the Day/Night Control value should always be zero.

The YY digits of the Day/Night Control Value determine when the Day/Night transition occurs. The Lux levels of the 12 settings are detailed in Appendix A. The accuracy of the light sensor is $\pm 10\%$.

To program night-only operation, set the required night intensity using the 1-1-XXX XXX command and set the day intensity to zero using the 1-2-000 000 command.

To program day and night operation, set the required night intensity using the 1-1-XXX XXX command and set the required day intensity using the 1-2-YYY YYY command.

4.7.4 Intensity Settings

The beacon is programmable in peak intensity during the flash. When a 'peak intensity during the flash' value is programmed into the beacon then no flash compensation is calculated and

the programmed intensity is used directly during the flash on period. The factory default reset will set this peak intensity programming mode. Refer to Appendix A for details.

Different peak intensity settings can be programmed for each of day and night operation. By having different intensity settings the beacon can be operated at a higher intensity during the day than at night to achieve similar visibility ranges. The programmable peak intensity settings are provided in Appendix B.

The beacon automatically adjusts the number of optics according to the required intensity setting. For VRL-74s with multiple optics, at very low programmed intensities the beacon will turn off all except one optic. This is done to achieve a wider range of programmable intensities, which makes the VRL-74 more versatile. The precise change-over intensity between all optics activated and only one optic activated depends on all of the beacon's color and LED version, the flash character and the ambient temperature. The table(s) in Appendix B show a cross-hatched area of programmable intensities in which the beacon's changeover of number of optics is likely to occur.

Operation	=Program (or read)	=1 (or 9)
Feature	=Intensity	=1 for night intensity, 2 for day intensity
Value	=Select from Appendix B	=XXX XXX

4.7.5 Synchronizing Options

Three options are available for synchronization on the beacons:

- Hard wired synchronization
- Internal GPS synchronization
- External GPS synchronization using Vega VSU-29 module

Hard wired synchronization can be used where the other beacons to be synchronized are within practical wiring distance. Otherwise GPS based synchronization can be used.

For Vega LED products the sync pulse has a positive to negative transition. Each light can be set to be a sync master or sync slave. As a slave the beacon will not generate sync pulses. As a master a sync pulse will occur at the start of the flash character. Where the lights connected are all masters the first light to send a sync pulse will control the other lights.

In slave mode the beacon will operate on the basis of the sync pulses received and will stop operating after a programmed number of flash cycles after the sync pulse is lost.

Operation	=Program (or read)	=1 (or 9)
Feature	=Synchronization	=3
Value		=XYY (999 disables

synchronization)

X determines if the light is a master or slave unit.

- 0YY Master
- 1YY Slave

YY allows for the start of the flash character to be delayed from 0.0 seconds to 9.9 seconds in 0.1second increments. For example YY=25 would provide a delay of 2.5 seconds.

When an external GPS sync unit is used, such as the Vega VSU-29, refer to the manual for this device.

4.7.6 Loss of Sync when in Slave Sync Mode

To program a slave beacon to keep running for a number of flash cycles after the loss of the master sync pulse.

Operation	=Program (or read)	=1 (or 9)
Feature	=Flash count on Loss of Sync	=7

Value =0YY where YY is the number of flashes (a minimum of 2 is recommended and is the default)

Programming a flash count of 998 will put the beacon into Sync low off mode – where the beacon will turn off if the sync line is grounded. Obviously normal sync will not work if this option is selected. Programming a flash count of 999 will turn off the Sync low off mode.

4.7.7 Operation Mode

The operation mode setting selects normal modes fail-safe or best-effort (this is the default), and also allows a test mode and a factory default reset. In the fail-safe mode, if a fault is detected then the beacon will stop operating and assert the alarm output (if fitted). In the best-effort mode, if a fault occurs then the beacon will attempt to continue operating, if practicable, as well as asserting the alarm output (if fitted). In best-effort mode, in some fault cases it will not be possible for the beacon to continue operating.

Operation	=Program (or read)	= 1 (or 9)
Feature	=Operation Mode	= 5
Value	=XXX	

The values that can be programmed are as follows:

001	Normal Mode – fail-safe
002	Normal Mode – best-effort (default)
008	Test Mode
998	USCG Factory Default Reset

Test Mode (008) will override whatever Operation mode the light is set to and allow the flash character to operate for 4 minutes. The intensity used for the flash will depend on whether the light considers the ambient light level as day or night. At the end of the 4 minute test period the light will revert back to the preset Normal Mode.

The factory default reset command causes the beacon to be reset into a simple operating mode with non-zero day and night intensities and a Q 1s 0.3 flash character. The purposes of this feature are to reassure the user that the beacon is powered up and working with familiar settings and to undo any programming mistakes (especially for the more complex features). A detailed description of the effects of the factory default reset is provided in Appendix A.

4.7.8 Battery Thresholds

The beacon has programmable battery threshold settings designed to protect a battery from damage by being over-discharged.

The beacon protects the power supply from low voltage damage and will switch off when the programmed low threshold is reached. This feature can be disabled. If the beacon detects three consecutive voltage readings less than the programmed low voltage threshold the beacon will turn off. Normal operation is resumed once a daylight transition is detected and the voltage exceeds the battery reconnect threshold value. When normal operation is restored after a low voltage condition, the beacon switches on for ten seconds before making a determination of day or night.

For a nominal 12V battery supply, the default values are 11.0V for the low voltage threshold (110), and 12.8V for the reconnect threshold (128). Setting the low voltage value to 999 will disable this function. Setting the reconnect threshold to 999 will reset both it back to the default value.

4.7.9 System Information

The beacons contain details of manufacture including calibration details, firmware version, and LED type used. See Appendix A for the full list of data available

For example the VRL-74 provides a reading of the supply voltage as a quick means of checking battery voltage.

Operation	=Read Only	=3
Feature	=Input Voltage	=1 (see Appendix A for others)
Value		=Series of flashes providing the requested value.

The input voltage value is provided in tenths of a volt.

5.0 Routine Maintenance

5.1 Maintenance Cleaning

Vega LED beacons require little to no maintenance.

The beacons should be inspected and cleaned occasionally to ensure maximum intensity and that no foreign material has got trapped in the heat sink on the rear of each unit.

Use warm soapy water to wash the outside of the beacon and rinse off with clean water. Do not use any solvent-based cleaner.

5.2 Inspection Check

Periodically check that the beacon remains firmly secured and level, and that the mounting fasteners are still in good condition. Investigate any corrosion and take appropriate preventive action.

User Notes

Appendix A VRL-74 and VRL-91 Programming Table

Operation	Feature	Value																																							
1 = Program Mode 9 = Read Settings	0 = Flash Character	000 – Fixed character 1YY – Iso phase (ISO) 2YY – Occulting (OC) 3YY – Flash (FI) 4YY - Multiple Flash (FI(x)) 5YY - Very Quick (VQ) 6YY - Quick (Q) 7YY – Long (LF) 8YY – Morse (MO) 9YY – Custom (Codes)																																							
	1 = Night Peak Intensity	Peak intensity during the flash. Refer to Appendix B for a table of available settings.																																							
	2 = Day Peak Intensity	Peak intensity during the flash. Refer to Appendix B for a table of available settings.																																							
1 = Program Mode 9 = Read Settings	3 = Synchronization <i>Factory setting: 000</i>	999 – Disable Synchronization 0YY Light in master mode 1YY Light in slave mode YY=sync delay seconds (0.0 to 9.9 seconds)																																							
	4 = Day/Night Control <i>Factory setting: 009</i>	0YY Format YY= Day/Night transition Lux Level <table border="1" style="margin-left: 20px;"> <thead> <tr> <th></th> <th>Night Lux.</th> <th>Day Lux</th> </tr> </thead> <tbody> <tr> <td>YY=01</td> <td>40</td> <td>100</td> </tr> <tr> <td>YY=02</td> <td>50</td> <td>150</td> </tr> <tr> <td>YY=03</td> <td>75</td> <td>100 CCG</td> </tr> <tr> <td>YY=04</td> <td>75</td> <td>150</td> </tr> <tr> <td>YY=05</td> <td>75</td> <td>175 IALA suggested</td> </tr> <tr> <td>YY=06</td> <td>100</td> <td>175</td> </tr> <tr> <td>YY=07</td> <td>100</td> <td>200</td> </tr> <tr> <td>YY=08</td> <td>150</td> <td>250</td> </tr> <tr> <td>YY=09</td> <td>250</td> <td>320 longest night</td> </tr> </tbody> </table> USCG <table border="1" style="margin-left: 20px;"> <tbody> <tr> <td>YY=10</td> <td>15</td> <td>40 shortest night</td> </tr> <tr> <td>YY=11</td> <td>30</td> <td>50</td> </tr> <tr> <td>YY=12</td> <td>15</td> <td>60</td> </tr> </tbody> </table>		Night Lux.	Day Lux	YY=01	40	100	YY=02	50	150	YY=03	75	100 CCG	YY=04	75	150	YY=05	75	175 IALA suggested	YY=06	100	175	YY=07	100	200	YY=08	150	250	YY=09	250	320 longest night	YY=10	15	40 shortest night	YY=11	30	50	YY=12	15	60
		Night Lux.	Day Lux																																						
	YY=01	40	100																																						
	YY=02	50	150																																						
YY=03	75	100 CCG																																							
YY=04	75	150																																							
YY=05	75	175 IALA suggested																																							
YY=06	100	175																																							
YY=07	100	200																																							
YY=08	150	250																																							
YY=09	250	320 longest night																																							
YY=10	15	40 shortest night																																							
YY=11	30	50																																							
YY=12	15	60																																							
5 = Operation Mode <i>Factory setting: 002</i>	001 – Normal Failsafe 002 – Normal Best Effort (Default) 008 – Test Mode 998 – Factory Default Reset																																								
7 = Additional Sync Options <i>Factory setting: 001</i>	0YY– Continue “Y” number of cycles (0-99) after loss of sync. 999 – Disable sync low off mode 998 – Beacon deactivated by holding sync low																																								
8 = Low battery threshold <i>Factory setting: 110</i>	YYY – Battery low threshold (00.0 to 12.0V, default setting is 11.0V) 999 – Disabled, No battery low cut off.																																								

Operation	Feature	Value
	9 = Battery reconnect threshold <i>Factory setting: 128</i>	YYY – Battery reconnect threshold (08.0 to 13.8V) 999 - reset to default setting (12.8V)
2 – Custom Character Setting	Custom flash character segments	Up to 9 On/Off pairs. Comma Separated, 50 millisecond units. Numbers 002 to 255 are permitted in the On/Off pairs. 001 is a special case indicating continuation (connect the two values on either side of 001) 002 to 255: 100 milliseconds to 12.75 seconds 001 - Extend an on or off period). 000 – End command Examples: a: 010 020 015 020 200 001 200 020 000 b: 006 012 006 012 000 c: 125 125 000 Illegal: a: 020 001 001 020 000 (repeated connecting character) b: 010 020 015 000 (no off period after 015) c: 020 010 020 010 (no terminating 000)
3 – System Checks	0 = Software version	Version Y.Y.Y (e.g. 210)
	1 – Battery voltage	YY.Y Volts (e.g. 11.7 volts) Last voltage prior to entering programming mode
	2 – Temperature Reading	Temperature of the electronics in degrees Kelvin (C+273)
	3 – Current adjustment	Percentage output adjust (100% only)
	4 – Serial Number	Displays beacon serial number as a series of flashes.
	5 – LED version number	Displays LED version number identifier
	6 – Characterization number	Displays LED characterization identifier
	7 – GPS option detected	000 – if GPS not detected 001 – if GPS detected

Operation	Feature	Value
	9 – Testing & Error Logging	002 – Display Battery Voltage in volts x 10 003 – Display Solar Voltage in volts x 10 004 – Temperature in Kelvin from default sensor 005 – Display raw light level reading in ADC counts 100 – Display master error code (0 = Good) 101 – Display logged error code (0 = none) 102 – Display logged error count 103 – Reset logged error code & error count, night counts & restart count 104 – Display night count before error 105 – Display night count between first & last errors 106 – Display night count after last error 107 – Display restart count

Factory Default Reset	
Programming Code	Reset Effects
1-5-998	The beacon is programmed with these settings: <ul style="list-style-type: none"> • Q 1s 0.3s (1-0-601) • Night intensity is set to half single optic max intensity • Day intensity is set to half full beacon max intensity • Master sync & zero sync delay set (1-3-000) • USCG day/night thresholds (1-4-009) • Normal Best Effort Mode (1-5-002) • Standard sync behavior (1-7-999, 1-7-002) • Low and reconnect battery thresholds reset to 12V nominal values • Peak Intensity Flash Mode (7-2-001) • Auto-storage and calendar modes are disabled.

Appendix B Intensity Settings And Currents
APPENDIX B.1 VRL-74 Optics

The VRL-74 product can be ordered with a range of horizontal divergence options and a fixed 3° vertical divergence. The basic product contains 3° x 3° primary optics (defined at 50% intensity points). The horizontal optical divergence options are implemented by factory-fitting of secondary spreader optics. The secondary optics are specified as divergence multipliers in each axis. For example, a 2H spreader option will create a 6° horizontal divergence (i.e. 2H* 3°=6°) defined at the 50% intensity points.

Note that the optics (both primary and secondary) in a VRL-74 Mini-Array product will always project parallel to each other. i.e. the widest divergence that can be ordered for a VRL-74 Mini-Array product is the same as the widest divergence available from a secondary lens.

Fitting of secondary spreader optics is normally performed in the factory and is covered by Vega’s warranty as to the divergence, intensity, power consumption and environmental specifications. User Manual documentation will be provided, and the beacon firmware programmed prior to shipment to correspond to the intensity available from the final assembly, including selected spreader optics. If a customer removes or fits spreader optics then the beacon’s User Manual specifications and firmware programming codes will no longer correspond to the beacon’s actual intensity.

Each VRL-74 product’s programmable intensity range is designed for the spreader and color ordered. The beacon should be programmed for the appropriate intensity desired for the specified color and beam angle provided by the fitted spreader. For example, a single-optic 3 degree yellow unit (i.e. no spreader fitted) is capable of up to 16.7kCd output intensity and it can be programmed at almost any value up to this maximum. Whereas, a single-optic yellow 2x1 (i.e. 6° x 3°) unit is only capable of 8.79kCd maximum output and can be programmed at almost any intensity up to this intensity value, and not beyond.

VRL-74 3°x3° Primary Optics’ Maximum Intensity					
Release Date: June 2017					
	R	G	W	Y	B
LED	168	263	465	366	562
1-Optic Maximum Intensity, kCD	33	37.7	96	33	13.6

Optional GPS pulse sync unit, current figures

The clock sync data update from the satellite is programmed to occur every 30 minutes for a typical duration of 2 minutes regardless of the beacon's programmed flash character.

Internal GPS pulse sync unit	Operating current (mA) at 25°C and 12VDC
"On" current, update from satellite	17
Base current, between updates	5
Sync off	0

Notes for the performance tables:

- Currents are based on 12V supply voltage.
- Currents are based on operation at an ambient temperature of 25°C.
- A +10% tolerance should be added to the currents shown.
- Currents are temperature-dependent, rising with increased temperature.
- The VRL-74 is rated to operate over the ambient temperature range of at least -30°C to +50°C.

Using the intensity programming tables:

1. The externally-controlled VRL-74 beacon is programmed for the peak intensity required. The programmed intensity is shown in the Intensity column for the relevant Prog Code entered. The programmed intensity is the peak intensity during the flash.
2. To program an intensity, enter the appropriate command and field codes using the programmer, followed by the six-digit intensity code listed in the appropriate row of the Prog Code column of the table. The Max Intensity value shown at the bottom of the table can also be programmed using either the appropriate Prog code or 999999. The beacon will safely operate at fixed character at any of these intensities at up to 50°C ambient.
3. The beacon is unable to output more than the maximum candela shown in the table. The user should check that the beacon is able to reach the peak candela required. The beacon will reject any intensity setting that is outside its legal range (both above and below its capability). All intensity values in the table up to and including the maximum value will be correctly output by the beacon.
4. To determine the on current of a flash read off the appropriate current consumption against the programmed peak intensity in the appropriate table. Add in the fixed current figure indicated at the bottom of the table. If the required intensity is not shown in the table then its current can be estimated from the currents of nearby entries.
5. The 'on current' and 'off current' of the beacon (indicated at the bottom of the table) should be taken into account in the power consumption calculations. The 'on current' is consumed during a flash and between flashes, so it has a 100% duty cycle, whereas the flash current only has the duty cycle relevant to the selected flash character. The 'off current' is consumed when zero intensity is set.

Appendix B.1.1 VRL-74 GREEN Intensity Settings And Currents

VRL-74 Range Light Performance Table 3° x 3°							Sep 2015
Intensity (Cd) **	Prog Code (six digits) **	GREEN 263 1x1 (No spreader)					
		Current (A) @25C, 12V					
		VRL-74- 111 1-optic product	VRL-74- 211 2-optic product	VRL-74- 311 3-optic product	VRL-74- 411 4-optic product	VRL-74- 511 5-optic product	VRL-74- 611 6-optic product
226,20 0	226 200						2.00
205,45 5	205 455						1.80
188,50 0	188 500					1.67	1.67
168,61 5	168 615					1.48	1.48
150,80 0	150 800				1.33	1.33	1.33
138,22 0	138 220				1.21	1.21	1.21
113,10 0	113 100			1.00	1.00	1.00	1.00
92,550	092 550			0.80	0.80	0.80	0.80
75,400	075 400		0.67	0.67	0.67	0.67	0.67
62,000	062 000		0.55	0.55	0.55	0.55	0.55
50,200	050 200		0.45	0.45	0.45	0.45	0.45
37,700	037 700	0.33	0.33	0.33	0.33	0.33	0.33
22,000	022 000	0.18	0.18	0.18	0.18	0.18	0.18
14,500	014 500	0.10	0.10	0.10	0.10	0.10	0.10
12,500	012 500	0.086					
3,664	003 664	0.025					
1,390	001 390	0.010					
488	000 488	0.0035					
145	000 145	0.001					
0	000 000	0					
Max Candela (kCD), -30C to +50C		37.7	75.4	113.1	150.8	188.5	226.2

Max Current (A @ 12V @ 25C)	0.33	0.67	1.0	1.33	1.67	2.0
Beacon On continuous current (A @ 12V)*	0.010	0.010	0.010	0.010	0.010	0.010
Beacon Off continuous current (A @ 12V)	0.010	0.010	0.010	0.010	0.010	0.010



Indicates the approximate crossover region between all optics active and one optic active.

* This current is continuously drawn during and between flashes, irrespective of the programmed intensity. It is additional to the intensity-related currents in the table above it.

**The beacon intensity programming is not limited to the values shown. Any value can be set within the specified range and within the available precision of the programming code.

VRL-74 Range Light Performance Table 6° x 3°							Sep 2015
Intensity (Cd) **	Prog Code (six digits) **	GREEN 263 2x1 Spreader					
		Current (A) @25C, 12V					
		VRL-74- 121 1-optic product	VRL-74- 221 2-optic product	VRL-74- 321 3-optic product	VRL-74- 421 4-optic product	VRL-74- 521 5-optic product	VRL-74- 621 6-optic product
100,53 3	100 533						2.00
92,550	092 550						1.84
83,777	083 777					1.67	1.67
75,400	075 400					1.5	1.50
67,022	067 022				1.33	1.33	1.33
62,000	062 000				1.22	1.22	1.22
50,266	050 266			1.00	1.00	1.00	1.00
37,700	037 700			0.75	0.75	0.75	0.75
33,511	033 511		0.67	0.67	0.67	0.67	0.67
22,000	022 000		0.45	0.45	0.45	0.45	0.45
16,755	016 755	0.33	0.33	0.33	0.33	0.33	0.33
14,126	014 126	0.25	0.25	0.25	0.25	0.25	0.25
9,100	009 100	0.15	0.15	0.15	0.15	0.15	0.15
6,444	006 444	0.10	0.10	0.10	0.10	0.10	0.10
5,555	005 555	0.056					
3,664	003 664	0.037					
1,390	001 390	0.014					
488	000 488	0.005					
64	000 064	0.0006					
0	000 000	0					
Max Candela (kCD), -30C to +50C		16.7	33.5	50.2	67.0	83.7	100.5

Max Current (A @ 12V @ 25C)	0.33	0.67	1.0	1.33	1.67	2.0
Beacon On continuous current (A @ 12V)*	0.010	0.010	0.010	0.010	0.010	0.010
Beacon Off continuous current (A @ 12V)	0.010	0.010	0.010	0.010	0.010	0.010



Indicates the approximate crossover region between all optics active and one optic active.

* This current is continuously drawn during and between flashes, irrespective of the programmed intensity. It is additional to the intensity-related currents in the table above it.

**The beacon intensity programming is not limited to the values shown. Any value can be set within the specified range and within the available precision of the programming code.

VRL-74 Range Light Performance Table 9° x 3°							Sep 2015
Intensity (Cd) **	Prog Code (six digits) **	GREEN 263 3x1 Spreader					
		Current (A) @25C, 12V					
		VRL-74- 131 1-optic product	VRL-74- 231 2-optic product	VRL-74- 331 3-optic product	VRL-74- 431 4-optic product	VRL-74- 531 5-optic product	VRL-74- 631 6-optic product
75,400	075 400						2.00
66,500	066 500						1.80
62,000	062 000					1.67	1.67
50,200	050 200				1.33	1.33	1.33
41,000	041 000				1.10	1.10	1.10
37,700	037 700			1.00	1.00	1.00	1.00
33,000	033 000			0.88	0.88	0.88	0.88
27,000	027 000			0.72	0.72	0.72	0.72
25,000	025 000		0.67	0.67	0.67	0.67	0.67
22,000	022 000		0.58	0.58	0.58	0.58	0.58
18,000	018 000		0.48	0.48	0.48	0.48	0.48
12,500	012 500	0.33	0.33	0.33	0.33	0.33	0.33
8,000	008 000	0.21	0.21	0.21	0.21	0.21	0.21
5,000	005 000	0.13	0.13	0.13	0.13	0.13	0.13
4,833	004 833	0.10	0.10	0.10	0.10	0.10	0.10
4,166	004 166	0.086					
1,390	001 390	0.029					
835	000 835	0.017					
488	000 488	0.010					
277	000 277	0.006					
48	000 048	0.001					
0	000 000	0					

Max Candela (kCD), -30C to +50C	12.5	25.1	37.7	50.2	62.8	75.4
Max Current (A @ 12V @ 25C)	0.33	0.67	1.0	1.33	1.67	2.0
Beacon On continuous current (A @ 12V)*	0.010	0.010	0.010	0.010	0.010	0.010
Beacon Off continuous current (A @ 12V)	0.010	0.010	0.010	0.010	0.010	0.010



Indicates the approximate crossover region between all optics active and one optic active.

** This current is continuously drawn during and between flashes, irrespective of the programmed intensity. It is additional to the intensity-related currents in the table above it.*

***The beacon intensity programming is not limited to the values shown. Any value can be set within the specified range and within the available precision of the programming code.*

VRL-74 Range Light Performance Table 12° x 3°							Sep 2015
Intensity (Cd) **	Prog Code (six digits) **	GREEN 263 4x1 Spreader					
		Current (A) @25C, 12V					
		VRL-74-141 1-optic product	VRL-74-241 2-optic product	VRL-74-341 3-optic product	VRL-74-441 4-optic product	VRL-74-541 5-optic product	VRL-74-641 6-optic product
58,000	058000						2.00
50,200	050200						1.73
48,333	048333					1.67	1.67
41,000	041000					1.41	1.41
38,666	038666				1.33	1.33	1.33
33,000	033000				1.13	1.13	1.13
29,000	029000			1.0	1.0	1.0	1.0
25,000	025000			0.85	0.85	0.85	0.85
19,333	019333		0.67	0.67	0.67	0.67	0.67
12,500	012500		0.41	0.41	0.41	0.41	0.41
9,666	009666	0.33	0.33	0.33	0.33	0.33	0.33
5,000	005000	0.15	0.15	0.15	0.15	0.15	0.15
3,717	003717	0.10	0.10	0.10	0.10	0.10	0.10
3,205	003205	0.086					
1,390	001390	0.037					
835	000835	0.022					
488	000488	0.013					
37	000037	0.001					
0	000000	0					
Max Candela (kCD), -30C to +50C		9.6	19.3	29.0	38.6	48.3	58.0
Max Current (A @ 12V @ 25C)		0.33	0.67	1.0	1.33	1.67	2.0

Beacon On continuous current (A @ 12V)*	0.010	0.010	0.010	0.010	0.010	0.010
Beacon Off continuous current (A @ 12V)	0.010	0.010	0.010	0.010	0.010	0.010



Indicates the approximate crossover region between all optics active and one optic active.

** This current is continuously drawn during and between flashes, irrespective of the programmed intensity. It is additional to the intensity-related currents in the table above it.*

***The beacon intensity programming is not limited to the values shown. Any value can be set within the specified range and within the available precision of the programming code.*

VRL-74 Range Light Performance Table 15° x 3°							Sep 2015
Intensity (Cd) **	Prog Code (six digits) **	GREEN 263 5x1 Spreader					
		Current (A) @25C, 12V					
		VRL-74- 151 1-optic product	VRL-74- 251 2-optic product	VRL-74- 351 3-optic product	VRL-74- 451 4-optic product	VRL-74- 551 5-optic product	VRL-74- 651 6-optic product
45,240	045 240						2.00
41,000	041 000						1.81
37,700	037 700					1.67	1.67
33,000	033 000					1.46	1.46
30,160	030 160				1.33	1.33	1.33
25,000	025 000				1.11	1.11	1.11
22,620	022 620			1.00	1.00	1.00	1.00
22,000	022 000			0.97	0.97	0.97	0.97
18,000	018 000			0.80	0.80	0.80	0.80
15,080	015 080		0.67	0.67	0.67	0.67	0.67
12,500	012 500		0.55	0.55	0.55	0.55	0.55
8,000	008 000		0.35	0.35	0.35	0.35	0.35
3,800	003 800	0.17	0.17	0.17	0.17	0.17	0.17
2,900	002 900	0.10	0.10	0.10	0.10	0.10	0.10
2,500	002 500	0.086					
835	000 835	0.029					
488	000 488	0.017					
277	000 277	0.010					
29	000 029	0.001					
0	000 000	0					
Max Candela (kCD), -30C to +50C		7.5	15.0	22.6	30.1	37.7	45.2

Max Current (A @ 12V @ 25C)	0.33	0.67	1.0	1.33	1.67	2.0
Beacon On continuous current (A @ 12V)*	0.010	0.010	0.010	0.010	0.010	0.010
Beacon Off continuous current (A @ 12V)	0.010	0.010	0.010	0.010	0.010	0.010



Indicates the approximate crossover region between all optics active and one optic active.

* This current is continuously drawn during and between flashes, irrespective of the programmed intensity. It is additional to the intensity-related currents in the table above it.

**The beacon intensity programming is not limited to the values shown. Any value can be set within the specified range and within the available precision of the programming code.

VRL-74 Range Light Performance Table 18° x 3°							Sep 2015
Intensity (Cd) **	Prog Code (six digits) **	GREEN 263 6x1 Spreader					
		Current (A) @25C, 12V					
		VRL-74- 161 1-optic product	VRL-74- 261 2-optic product	VRL-74- 361 3-optic product	VRL-74- 461 4-optic product	VRL-74- 561 5-optic product	VRL-74- 661 6-optic product
40,392	040 392						2.00
37,700	037 700						1.87
33,660	033 660					1.67	1.67
30,100	030 100					1.48	1.48
26,928	026 928				1.33	1.33	1.33
25,000	025 000				1.23	1.23	1.23
22,000	022 000				1.08	1.08	1.08
20,196	020 196			1.00	1.00	1.00	1.00
15,000	015 000			0.72	0.72	0.72	0.72
13,464	013 464		0.67	0.67	0.67	0.67	0.67
8,000	008 000		0.37	0.37	0.37	0.37	0.37
6,732	006 732	0.33	0.33	0.33	0.33	0.33	0.33
3,800	003 800	0.16	0.16	0.16	0.16	0.16	0.16
2,589	002 589	0.10	0.10	0.10	0.10	0.10	0.10
2,232	002 232	0.086					
835	000 835	0.032					
488	000 488	0.019					
277	000 277	0.011					
25	000 025	0.001					
0	000 000	0					
Max Candela (kCD), -30C to +50C		6.7	13.4	20.1	26.9	33.6	40.3

Max Current (A @ 12V @ 25C)	0.33	0.67	1.0	1.33	1.67	2.0
Beacon On continuous current (A @ 12V)*	0.010	0.010	0.010	0.010	0.010	0.010
Beacon Off continuous current (A @ 12V)	0.010	0.010	0.010	0.010	0.010	0.010



Indicates the approximate crossover region between all optics active and one optic active.

* This current is continuously drawn during and between flashes, irrespective of the programmed intensity. It is additional to the intensity-related currents in the table above it.

**The beacon intensity programming is not limited to the values shown. Any value can be set within the specified range and within the available precision of the programming code.

Appendix B.1.2 VRL-74 WHITE Intensity Settings And Currents

VRL-74 Range Light Performance Table 3° x 3°							Jun 2017
Intensity (Cd) **	Prog Code (six digits) **	WHITE 465 1x1 (No spreader)					
		Current (A) @25C, 12V					
		VRL-74- 111 1-optic product	VRL-74- 211 2-optic product	VRL-74- 311 3-optic product	VRL-74- 411 4-optic product	VRL-74- 511 5-optic product	VRL-74- 611 6-optic product
576,00 0	576 000	-	-	-	-	-	2.40
543,00 0	543 000	-	-	-	-	-	2.26
480,00 0	480 000	-	-	-	-	2.00	2.00
384,00 0	384 000	-	-	-	1.60	1.60	1.60
320,00 0	320 000	-	-	-	1.33	1.34	1.34
288,00 0	288 000	-	-	1.20	1.20	1.20	1.20
222,50 0	222 500	-	-	0.93	0.93	0.93	0.93
192,00 0	192 000	-	0.80	0.80	0.80	0.80	0.80
150,80 0	150 800	-	0.63	0.63	0.63	0.63	0.63
96,000	096 000	0.40	0.40	0.40	0.40	0.40	0.41
62,000	062 000	0.26	0.26	0.26	0.26	0.26	0.26
50,200	050 200	0.21	0.21	0.21	0.21	0.21	0.21
22,000	022 000	0.10	0.10	0.10	0.10	0.10	0.10
14,500	014 500	0.07					
12,500	012 500	0.06					
3,664	003 664	0.02					
148	000 148	0.00					
0	000 000	0.00					
Max Candela (kCD), -30C to +50C		96.0	192.0	288.0	384.0	480.0	576.0
Max Current (A @ 12V @ 25C)		0.4	0.8	1.2	1.6	2.0	2.4

Beacon On continuous current (A @ 12V)*	0.010	0.010	0.010	0.010	0.010	0.010
Beacon Off continuous current (A @ 12V)	0.010	0.010	0.010	0.010	0.010	0.010



Indicates the approximate crossover region between all optics active and one optic active.

** This current is continuously drawn during and between flashes, irrespective of the programmed intensity. It is additional to the intensity-related currents in the table above it.*

***The beacon intensity programming is not limited to the values shown. Any value can be set within the specified range and within the available precision of the programming code.*

VRL-74 Range Light Performance Table 6° x 3°							Jun 2017
Intensity (Cd) **	Prog Code (six digits) **	WHITE 465 2x1 Spreader					
		Current (A) @25C, 12V					
		VRL-74- 121 1-optic product	VRL-74- 221 2-optic product	VRL-74- 321 3-optic product	VRL-74- 421 4-optic product	VRL-74- 521 5-optic product	VRL-74- 621 6-optic product
274,20 0	274 200	-	-	-	-	-	2.40
228,50 0	228 500	-	-	-	-	2.00	2.00
205,45 5	205 455	-	-	-	-	1.80	1.80
182,80 0	182 800	-	-	-	1.60	1.60	1.60
150,80 0	150 800	-	-	-	1.32	1.32	1.32
137,10 0	137 100	-	-	1.20	1.20	1.20	1.20
113,10 0	113 100	-	-	0.99	0.99	0.99	0.99
91,400	091 400	-	0.80	0.80	0.80	0.80	0.80
50,200	050 200	-	0.44	0.44	0.44	0.44	0.44
45,700	045 700	0.40	0.40	0.40	0.40	0.40	0.41
22,000	022 000	0.20	0.20	0.20	0.20	0.20	0.20
9,100	009 100	0.09	0.09	0.09	0.09	0.09	0.09
7,100	007 100	0.07					
3,664	003 664	0.04					
1,390	001 390	0.01					
70	000 070	0.00					
0	000 000	0					
Max Candela (kCD), -30C to +50C		45.7	91.4	137.1	182.8	228.5	274.2
Max Current (A @ 12V @ 25C)		0.4	0.8	1.2	1.6	2.0	2.4
Beacon On continuous current (A @ 12V)*		0.010	0.010	0.010	0.010	0.010	0.010

Beacon Off continuous current (A @ 12V)	0.010	0.010	0.010	0.010	0.010	0.010
--	--------------	--------------	--------------	--------------	--------------	--------------



Indicates the approximate crossover region between all optics active and one optic active.

** This current is continuously drawn during and between flashes, irrespective of the programmed intensity. It is additional to the intensity-related currents in the table above it.*

***The beacon intensity programming is not limited to the values shown. Any value can be set within the specified range and within the available precision of the programming code.*

VRL-74 Range Light Performance Table 9° x 3°							Jun 2017
Intensity (Cd) **	Prog Code (six digits) **	WHITE 465 3x1 Spreader					
		Current (A) @25C, 12V					
		VRL-74- 131 1-optic product	VRL-74- 231 2-optic product	VRL-74- 331 3-optic product	VRL-74- 431 4-optic product	VRL-74- 531 5-optic product	VRL-74- 631 6-optic product
174,50 0	174 500	-	-	-	-	-	2.40
168,61 5	168 615	-	-	-	-	-	2.32
145,40 0	145 400	-	-	-	-	2.00	2.00
138,22 0	138 220	-	-	-	-	1.90	1.90
116,30 0	116 300	-	-	-	1.60	1.60	1.60
92,550	092 550	-	-	-	1.27	1.28	1.28
87,200	087 200	-	-	1.20	1.20	1.20	1.20
76,100	076 100	-	-	1.05	1.05	1.05	1.05
58,100	058 100	-	0.80	0.80	0.80	0.80	0.80
37,700	037 700	-	0.52	0.52	0.52	0.52	0.52
29,000	029 000	0.40	0.40	0.40	0.40	0.40	0.40
5,600	005 600	0.08	0.08	0.08	0.08	0.08	0.08
4,500	004 500	0.07					
3,664	003 664	0.05					
1,390	001 390	0.02					
45	000 045	0.00					
0	000 000	0					
Max Candela (kCD), -30C to +50C		29.0	58.1	87.2	116.3	145.4	174.5
Max Current (A @ 12V @ 25C)		0.4	0.8	1.2	1.6	2.0	2.4
Beacon On continuous current (A @ 12V)*		0.010	0.010	0.010	0.010	0.010	0.010

Beacon Off continuous current (A @ 12V)	0.010	0.010	0.010	0.010	0.010	0.010
--	--------------	--------------	--------------	--------------	--------------	--------------



Indicates the approximate crossover region between all optics active and one optic active.

** This current is continuously drawn during and between flashes, irrespective of the programmed intensity. It is additional to the intensity-related currents in the table above it.*

***The beacon intensity programming is not limited to the values shown. Any value can be set within the specified range and within the available precision of the programming code.*

VRL-74 Range Light Performance Table 12° x 3°							Jun 2017
Intensity (Cd) **	Prog Code (six digits) **	WHITE 465 4x1 Spreader					
		Current (A) @25C, 12V					
		VRL-74- 141 1-optic product	VRL-74- 241 2-optic product	VRL-74- 341 3-optic product	VRL-74- 441 4-optic product	VRL-74- 541 5-optic product	VRL-74- 641 6-optic product
133,90 0	133 900	-	-	-	-	-	2.40
120,40 0	120 400	-	-	-	-	-	2.16
111,60 0	111 600	-	-	-	-	2.00	2.00
96,285	096 285	-	-	-	-	1.73	1.73
89,300	089 300	-	-	-	1.60	1.60	1.60
76,000	076 000	-	-	-	1.36	1.36	1.36
66,900	066 900	-	-	1.20	1.20	1.20	1.20
62,000	062 000	-	-	1.11	1.11	1.11	1.11
44,600	044 600	-	0.80	0.80	0.80	0.80	0.80
37,700	037 700	-	0.68	0.68	0.68	0.68	0.68
22,300	022 300	0.40	0.40	0.40	0.40	0.40	0.40
4,300	004 300	0.08	0.08	0.08	0.08	0.08	0.08
3,500	003 500	0.07					
1,390	001 390	0.03					
488	000 488	0.01					
34	000 034	0.00					
0	000 000	0					
Max Candela (kCD), -30C to +50C		22.3	44.6	66.9	89.3	111.6	133.9
Max Current (A @ 12V @ 25C)		0.4	0.8	1.2	1.6	2.0	2.4
Beacon On continuous current (A @ 12V)*		0.010	0.010	0.010	0.010	0.010	0.010

Beacon Off continuous current (A @ 12V)	0.010	0.010	0.010	0.010	0.010	0.010
--	--------------	--------------	--------------	--------------	--------------	--------------



Indicates the approximate crossover region between all optics active and one optic active.

** This current is continuously drawn during and between flashes, irrespective of the programmed intensity. It is additional to the intensity-related currents in the table above it.*

***The beacon intensity programming is not limited to the values shown. Any value can be set within the specified range and within the available precision of the programming code.*

VRL-74 Range Light Performance Table 15° x 3°							Jun 2017
Intensity (Cd) **	Prog Code (six digits) **	WHITE 465 5x1 Spreader					
		Current (A) @25C, 12V					
		VRL-74- 151 1-optic product	VRL-74- 251 2-optic product	VRL-74- 351 3-optic product	VRL-74- 451 4-optic product	VRL-74- 551 5-optic product	VRL-74- 651 6-optic product
115,200	115200	-	-	-	-	-	2.40
111,600	111600	-	-	-	-	-	2.33
96,000	096000	-	-	-	-	2.00	2.00
89,300	089300	-	-	-	-	1.86	1.86
76,800	076800	-	-	-	1.60	1.60	1.60
66,900	066900	-	-	-	1.39	1.40	1.40
57,600	057600	-	-	1.20	1.20	1.20	1.20
44,600	044600	-	-	0.93	0.93	0.93	0.93
38,400	038400	-	0.80	0.80	0.80	0.80	0.80
22,300	022300	-	0.47	0.47	0.47	0.47	0.47
19,200	019200	0.40	0.40	0.40	0.40	0.40	0.41
3,700	003700	0.08	0.08	0.08	0.08	0.08	0.08
3,000	003000	0.07					
1,390	001390	0.03					
488	000488	0.01					
29	00029	0.00					
0	000000	0					
Max Candela (kCD), -30C to +50C		19.2	38.4	57.6	76.8	96	115.2
Max Current (A @ 12V @ 25C)		0.4	0.8	1.2	1.6	2.0	2.4
Beacon On continuous current (A @ 12V)*		0.010	0.010	0.010	0.010	0.010	0.010

Beacon Off continuous current (A @ 12V)	0.010	0.010	0.010	0.010	0.010	0.010
--	--------------	--------------	--------------	--------------	--------------	--------------



Indicates the approximate crossover region between all optics active and one optic active.

** This current is continuously drawn during and between flashes, irrespective of the programmed intensity. It is additional to the intensity-related currents in the table above it.*

***The beacon intensity programming is not limited to the values shown. Any value can be set within the specified range and within the available precision of the programming code.*

VRL-74 Range Light Performance Table 18° x 3°							Jun 2017
Intensity (Cd) **	Prog Code (six digits) **	WHITE 465 6x1 Spreader					
		Current (A) @25C, 12V					
		VRL-74- 161 1-optic product	VRL-74- 261 2-optic product	VRL-74- 361 3-optic product	VRL-74- 461 4-optic product	VRL-74- 561 5-optic product	VRL-74- 661 6-optic product
108,600	108600	-	-	-	-	-	2.40
96,000	096000	-	-	-	-	-	2.12
90,500	090500	-	-	-	-	2.00	2.00
89,300	089300	-	-	-	-	1.97	1.97
72,400	072400	-	-	-	1.60	1.60	1.60
66,900	066900	-	-	-	1.48	1.48	1.48
54,300	054300	-	-	1.20	1.20	1.20	1.20
44,600	044600	-	-	0.99	0.99	0.99	0.99
36,200	036200	-	0.80	0.80	0.80	0.80	0.80
22,300	022300	-	0.50	0.50	0.50	0.50	0.50
18,100	018100	0.40	0.40	0.40	0.40	0.40	0.40
14,500	014500	0.32	0.32	0.32	0.33	0.33	0.33
3,500	003500	0.08	0.08	0.08	0.08	0.08	0.08
2,800	002800	0.07					
1,390	001390	0.03					
488	000488	0.01					
28	00028	0.00					
0	000000	0					
Max Candela (kCD), -30C to +50C		18.1	36.2	54.3	72.4	90.5	108.6
Max Current (A @ 12V @ 25C)		0.4	0.8	1.2	1.6	2.0	2.4

Beacon On continuous current (A @ 12V)*	0.010	0.010	0.010	0.010	0.010	0.010
Beacon Off continuous current (A @ 12V)	0.010	0.010	0.010	0.010	0.010	0.010



Indicates the approximate crossover region between all optics active and one optic active.

** This current is continuously drawn during and between flashes, irrespective of the programmed intensity. It is additional to the intensity-related currents in the table above it.*

***The beacon intensity programming is not limited to the values shown. Any value can be set within the specified range and within the available precision of the programming code.*

Appendix B.1.3 VRL-74 RED Intensity Settings And Currents

VRL-74 Range Light Performance Table 3° x 3°							Jun 2017
Intensity (Cd) **	Prog Code (six digits) **	RED 168 1x1 (No spreader)					
		Current (A) @25C, 12V					
		VRL-74-111 1-optic product	VRL-74-211 2-optic product	VRL-74-311 3-optic product	VRL-74-411 4-optic product	VRL-74-511 5-optic product	VRL-74-611 6-optic product
198,000	198000	-	-	-	-	-	1.38
188,500	188500	-	-	-	-	-	1.31
165,000	165000	-	-	-	-	1.15	1.15
150,800	150800	-	-	-	-	1.05	1.05
132,000	132000	-	-	-	0.92	0.92	0.92
113,100	113100	-	-	-	0.79	0.79	0.79
99,000	099000	-	-	0.69	0.69	0.69	0.69
75,400	075400	-	-	0.52	0.52	0.52	0.52
66,000	066000	-	0.46	0.46	0.46	0.46	0.46
50,200	050200	-	0.35	0.35	0.35	0.35	0.34
33,000	033000	0.23	0.23	0.23	0.22	0.22	0.22
22,000	022000	0.15	0.15	0.15	0.15	0.15	0.15
8,500	008500	0.05	0.05	0.05	0.05	0.05	0.05
6,000	006000	0.04					
3,664	003664	0.02					
1,390	001390	0.01					
488	000488	0.00					
60	000060	0.00					
0	000000	0					
Max Candela (kCD), -30C to +50C		33.0	66.0	99.0	132.0	165.0	198.0
Max Current (A @ 12V @ 25C)		0.23	0.46	0.69	0.92	1.15	1.38

Beacon On continuous current (A @ 12V)*	0.010	0.010	0.010	0.010	0.010	0.010
Beacon Off continuous current (A @ 12V)	0.010	0.010	0.010	0.010	0.010	0.010



Indicates the approximate crossover region between all optics active and one optic active.

** This current is continuously drawn during and between flashes, irrespective of the programmed intensity. It is additional to the intensity-related currents in the table above it.*

***The beacon intensity programming is not limited to the values shown. Any value can be set within the specified range and within the available precision of the programming code.*

VRL-74 Range Light Performance Table 6° x 3°							Jun 2017
Intensity (Cd) **	Prog Code (six digits) **	RED 168 2x1 Spreader					
		Current (A) @25C, 12V					
		VRL-74- 121 1-optic product	VRL-74- 221 2-optic product	VRL-74- 321 3-optic product	VRL-74- 421 4-optic product	VRL-74- 521 5-optic product	VRL-74- 621 6-optic product
99,000	099 000	-	-	-	-	-	1.38
87,770	087 770	-	-	-	-	-	1.22
82,500	082 500	-	-	-	-	1.15	1.15
76,100	076 100	-	-	-	-	1.06	1.06
66,000	066 000	-	-	-	0.92	0.92	0.92
56,300	056 300	-	-	-	0.78	0.78	0.78
49,500	049 500	-	-	0.69	0.69	0.69	0.69
40,650	040 650	-	-	0.57	0.56	0.56	0.56
33,000	033 000	-	0.46	0.46	0.46	0.46	0.46
25,000	025 000	-	0.35	0.35	0.34	0.34	0.34
16,500	016 500	0.23	0.23	0.23	0.22	0.22	0.22
8,560	008 560	0.12	0.11	0.11	0.11	0.11	0.11
5,100	005 100	0.07	0.06	0.06	0.06	0.06	0.06
3,000	003 000	0.04					
1,390	001 390	0.02					
488	000 488	0.01					
150	000 150	0.00					
30	000 030	0.00					
0	000 000	0					
Max Candela (kCD), -30C to +50C		16.5	33	49.5	66	82.5	99
Max Current (A @ 12V @ 25C)		0.23	0.46	0.69	0.92	1.15	1.38

Beacon On continuous current (A @ 12V)*	0.010	0.010	0.010	0.010	0.010	0.010
Beacon Off continuous current (A @ 12V)	0.010	0.010	0.010	0.010	0.010	0.010



Indicates the approximate crossover region between all optics active and one optic active.

** This current is continuously drawn during and between flashes, irrespective of the programmed intensity. It is additional to the intensity-related currents in the table above it.*

***The beacon intensity programming is not limited to the values shown. Any value can be set within the specified range and within the available precision of the programming code.*

VRL-74 Range Light Performance Table 9° x 3°							Jun 2017
Intensity (Cd) **	Prog Code (six digits) **	RED 168 3x1 Spreader					
		Current (A) @25C, 12V					
		VRL-74- 131 1-optic product	VRL-74- 231 2-optic product	VRL-74- 331 3-optic product	VRL-74- 431 4-optic product	VRL-74- 531 5-optic product	VRL-74- 631 6-optic product
63,800	063 800	-	-	-	-	-	1.38
56,300	056 300	-	-	-	-	-	1.22
53,200	053 200	-	-	-	-	1.15	1.15
50,200	050 200	-	-	-	-	1.08	1.08
42,500	042 500	-	-	-	0.92	0.92	0.92
37,700	037 700	-	-	-	0.81	0.81	0.81
31,900	031 900	-	-	0.69	0.69	0.69	0.69
25,000	025 000	-	-	0.54	0.54	0.54	0.54
21,200	021 200	-	0.46	0.46	0.45	0.45	0.45
16,500	016 500	-	0.36	0.35	0.35	0.35	0.35
10,600	010 600	0.23	0.23	0.22	0.22	0.22	0.22
8,560	008 560	0.18	0.18	0.18	0.18	0.18	0.18
3,290	003 290	0.07	0.06	0.06	0.06	0.06	0.06
1,935	001 935	0.04					
1,390	001 390	0.03					
488	000 488	0.01					
150	000 150	0.00					
19	000 019	0.00					
0	000 000	0					
Max Candela (kCD), -30C to +50C		10.6	21.2	31.9	42.5	53.2	63.8
Max Current (A @ 12V @ 25C)		0.23	0.46	0.69	0.92	1.15	1.38

Beacon On continuous current (A @ 12V)*	0.010	0.010	0.010	0.010	0.010	0.010
Beacon Off continuous current (A @ 12V)	0.010	0.010	0.010	0.010	0.010	0.010



Indicates the approximate crossover region between all optics active and one optic active.

** This current is continuously drawn during and between flashes, irrespective of the programmed intensity. It is additional to the intensity-related currents in the table above it.*

***The beacon intensity programming is not limited to the values shown. Any value can be set within the specified range and within the available precision of the programming code.*

VRL-74 Range Light Performance Table 12° x 3°							Jun 2017
Intensity (Cd) **	Prog Code (six digits) **	RED 168 4x1 Spreader					
		Current (A) @25C, 12V					
		VRL-74- 141 1-optic product	VRL-74- 241 2-optic product	VRL-74- 341 3-optic product	VRL-74- 441 4-optic product	VRL-74- 541 5-optic product	VRL-74- 641 6-optic product
50,700	050 700	-	-	-	-	-	1.38
45,700	045 700	-	-	-	-	-	1.24
42,300	042 300	-	-	-	-	1.15	1.15
37,700	037 700	-	-	-	-	1.02	1.02
33,800	033 800	-	-	-	0.92	0.92	0.92
28,000	028 000	-	-	-	0.76	0.76	0.76
25,300	025 300	-	-	0.69	0.69	0.69	0.68
22,000	022 000	-	-	0.60	0.60	0.59	0.59
16,900	016 900	-	0.46	0.46	0.46	0.46	0.45
12,500	012 500	-	0.34	0.34	0.34	0.33	0.33
8,400	008 400	0.23	0.22	0.22	0.22	0.22	0.22
5,100	005 100	0.14	0.13	0.13	0.13	0.13	0.13
2,615	002 615	0.07	0.06	0.06	0.06	0.06	0.06
1,540	001 540	0.04					
1,390	001 390	0.03					
488	000 488	0.01					
145	000 145	0.00					
15	000 015	0.00					
0	000 000	0					
Max Candela (kCD), -30C to +50C		8.4	16.9	25.3	33.8	42.3	50.7
Max Current (A @ 12V @ 25C)		0.23	0.46	0.69	0.92	1.15	1.38

Beacon On continuous current (A @ 12V)*	0.010	0.010	0.010	0.010	0.010	0.010
Beacon Off continuous current (A @ 12V)	0.010	0.010	0.010	0.010	0.010	0.010



Indicates the approximate crossover region between all optics active and one optic active.

** This current is continuously drawn during and between flashes, irrespective of the programmed intensity. It is additional to the intensity-related currents in the table above it.*

***The beacon intensity programming is not limited to the values shown. Any value can be set within the specified range and within the available precision of the programming code.*

VRL-74 Range Light Performance Table 15° x 3°							Jun 2017
Intensity (Cd) **	Prog Code (six digits) **	RED 168 5x1 Spreader					
		Current (A) @25C, 12V					
		VRL-74- 151 1-optic product	VRL-74- 251 2-optic product	VRL-74- 351 3-optic product	VRL-74- 451 4-optic product	VRL-74- 551 5-optic product	VRL-74- 651 6-optic product
38,800	038 800	-	-	-	-	-	1.38
37,700	037 700	-	-	-	-	-	1.34
32,300	032 300	-	-	-	-	1.15	1.15
28,000	028 000	-	-	-	-	0.99	0.99
25,800	025 800	-	-	-	0.92	0.92	0.92
22,000	022 000	-	-	-	0.78	0.78	0.78
19,400	019 400	-	-	0.69	0.69	0.69	0.69
16,900	016 900	-	-	0.60	0.60	0.60	0.60
12,900	012 900	-	0.46	0.46	0.46	0.45	0.45
8,400	008 400	-	0.30	0.29	0.29	0.29	0.29
6,400	006 400	0.23	0.22	0.22	0.22	0.22	0.22
3,290	003 290	0.11	0.11	0.11	0.11	0.11	0.11
2,000	002 000	0.07	0.06	0.06	0.06	0.06	0.06
1,180	001 180	0.04					
835	000 835	0.03					
488	000 488	0.02					
145	000 145	0.00					
12	000 012	0.00					
Max Candela (kCD), -30C to +50C		6.4	12.9	19.4	25.8	32.3	38.8
Max Current (A @ 12V @ 25C)		0.23	0.46	0.69	0.92	1.15	1.38

Beacon On continuous current (A @ 12V)*	0.010	0.010	0.010	0.010	0.010	0.010
Beacon Off continuous current (A @ 12V)	0.010	0.010	0.010	0.010	0.010	0.010



Indicates the approximate crossover region between all optics active and one optic active.

** This current is continuously drawn during and between flashes, irrespective of the programmed intensity. It is additional to the intensity-related currents in the table above it.*

***The beacon intensity programming is not limited to the values shown. Any value can be set within the specified range and within the available precision of the programming code.*

VRL-74 Range Light Performance Table 18° x 3°							Jun 2017
Intensity (Cd) **	Prog Code (six digits) **	RED 168 6x1 Spreader					
		Current (A) @25C, 12V					
		VRL-74- 161 1-optic product	VRL-74- 261 2-optic product	VRL-74- 361 3-optic product	VRL-74- 461 4-optic product	VRL-74- 561 5-optic product	VRL-74- 661 6-optic product
32,400	032 400	-	-	-	-	-	1.38
28,000	028 000	-	-	-	-	-	1.19
27,000	027 000	-	-	-	-	1.15	1.15
25,800	025 800	-	-	-	-	1.10	1.10
21,600	021 600	-	-	-	0.92	0.92	0.92
19,400	019 400	-	-	-	0.82	0.82	0.82
16,200	016 200	-	-	0.69	0.69	0.69	0.69
12,900	012 900	-	-	0.55	0.55	0.54	0.54
10,800	010 800	-	0.46	0.46	0.46	0.46	0.45
8,400	008 400	-	0.36	0.35	0.35	0.35	0.35
5,400	005 400	0.23	0.23	0.22	0.22	0.22	0.22
3,290	003 290	0.14	0.13	0.13	0.13	0.13	0.13
1,672	001 672	0.07	0.06	0.06	0.06	0.06	0.06
984	000 984	0.04					
835	000 835	0.03					
488	000 488	0.02					
145	000 145	0.01					
10	000 010	0.00					
0	000 000	0					
Max Candela (kCD), -30C to +50C		5.4	10.8	16.2	21.6	27	32.4
Max Current (A @ 12V @ 25C)		0.23	0.46	0.69	0.92	1.15	1.38

Beacon On continuous current (A @ 12V)*	0.010	0.010	0.010	0.010	0.010	0.010
Beacon Off continuous current (A @ 12V)	0.010	0.010	0.010	0.010	0.010	0.010



Indicates the approximate crossover region between all optics active and one optic active.

** This current is continuously drawn during and between flashes, irrespective of the programmed intensity. It is additional to the intensity-related currents in the table above it.*

***The beacon intensity programming is not limited to the values shown. Any value can be set within the specified range and within the available precision of the programming code.*

Appendix B.1.4 VRL-74 YELLOW Intensity Settings And Currents

VRL-74 Range Light Performance Table 3° x 3°							Jun 2017
Intensity (Cd) **	Prog Code (six digits) **	YELLOW 366 1x1 (No spreader)					
		Current (A) @25C, 12V					
		VRL-74-111 1-optic product	VRL-74-211 2-optic product	VRL-74-311 3-optic product	VRL-74-411 4-optic product	VRL-74-511 5-optic product	VRL-74-611 6-optic product
198,000	198000	-	-	-	-	-	2.64
188,500	188500	-	-	-	-	-	2.51
165,000	165000	-	-	-	-	2.20	2.20
150,800	150800	-	-	-	-	2.01	2.01
132,000	132000	-	-	-	1.76	1.76	1.76
113,100	113100	-	-	-	1.51	1.51	1.51
99,000	099000	-	-	1.32	1.32	1.32	1.32
75,400	075400	-	-	1.01	1.01	1.01	1.01
66,000	066000	-	0.88	0.88	0.88	0.88	0.88
50,200	050200	-	0.67	0.67	0.67	0.67	0.67
33,000	033000	0.44	0.44	0.44	0.44	0.44	0.44
16,500	016500	0.22	0.22	0.22	0.22	0.22	0.22
5,900	005900	0.08	0.08	0.08	0.08	0.08	0.08
5,570	005570	0.08					
3,664	003664	0.05					
1,390	001390	0.02					
488	000488	0.01					
56	000056	0.00					
0	000000	0.00					
Max Candela (kCD), -30C to +50C		33	66	99	132	165	198

Max Current (A @ 12V @ 25C)	0.44	0.88	1.32	1.76	2.20	2.64
Beacon On continuous current (A @ 12V)*	0.010	0.010	0.010	0.010	0.010	0.010
Beacon Off continuous current (A @ 12V)	0.010	0.010	0.010	0.010	0.010	0.010



Indicates the approximate crossover region between all optics active and one optic active.

* This current is continuously drawn during and between flashes, irrespective of the programmed intensity. It is additional to the intensity-related currents in the table above it.

**The beacon intensity programming is not limited to the values shown. Any value can be set within the specified range and within the available precision of the programming code.

VRL-74 Range Light Performance Table 6° x 3°							Jun 2017
Intensity (Cd) **	Prog Code (six digits) **	YELLOW 366 2x1 Spreader					
		Current (A) @25C, 12V					
		VRL-74- 121 1-optic product	VRL-74- 221 2-optic product	VRL-74- 321 3-optic product	VRL-74- 421 4-optic product	VRL-74- 521 5-optic product	VRL-74- 621 6-optic product
104,200	104200	-	-	-	-	-	2.64
99,000	099000	-	-	-	-	-	2.51
86,800	086800	-	-	-	-	2.20	2.20
76,100	076100	-	-	-	-	1.93	1.93
69,400	069400	-	-	-	1.76	1.76	1.76
56,300	056300	-	-	-	1.43	1.43	1.43
52,100	052100	-	-	1.32	1.32	1.32	1.32
40,650	040650	-	-	1.03	1.03	1.03	1.03
34,700	034700	-	0.88	0.88	0.88	0.88	0.88
25,000	025000	-	0.63	0.63	0.64	0.64	0.64
17,300	017300	0.44	0.44	0.44	0.44	0.44	0.44
8,560	008560	0.22	0.22	0.22	0.22	0.22	0.22
3,100	003100	0.08	0.08	0.08	0.08	0.08	0.08
2,930	002930	0.08					
1,390	001390	0.04					
488	000488	0.01					
150	000150	0.00					
29	000029	0.00					
0	000000	0.00					
Max Candela (kCD), -30C to +50C		17.3	34.7	52.1	69.4	86.8	104.2
Max Current (A @ 12V @ 25C)		0.44	0.88	1.32	1.76	2.20	2.64

Beacon On continuous current (A @ 12V)*	0.010	0.010	0.010	0.010	0.010	0.010
Beacon Off continuous current (A @ 12V)	0.010	0.010	0.010	0.010	0.010	0.010



Indicates the approximate crossover region between all optics active and one optic active.

** This current is continuously drawn during and between flashes, irrespective of the programmed intensity. It is additional to the intensity-related currents in the table above it.*

***The beacon intensity programming is not limited to the values shown. Any value can be set within the specified range and within the available precision of the programming code.*

VRL-74 Range Light Performance Table 9° x 3°							Jun 2017
Intensi-ty (Cd)**	Prog Code (six digits)**	YELLOW 366 3x1 Spreader					
		Current (A) @25C, 12V					
		VRL-74-131 1-optic product	VRL-74-231 2-optic product	VRL-74-331 3-optic product	VRL-74-431 4-optic product	VRL-74-531 5-optic product	VRL-74-631 6-optic product
66,000	066000	-	-	-	-	-	2.64
62,000	062000	-	-	-	-	-	2.48
55,000	055000	-	-	-	-	2.20	2.20
50,200	050200	-	-	-	-	2.01	2.01
45,700	045700	-	-	-	-	1.83	1.83
44,000	044000	-	-	-	1.76	1.76	1.76
37,700	037700	-	-	-	1.51	1.51	1.51
33,000	033000	-	-	1.32	1.32	1.32	1.32
25,000	025000	-	-	1.00	1.00	1.00	1.00
22,000	022000	-	0.88	0.88	0.88	0.88	0.88
14,500	014500	-	0.58	0.58	0.58	0.58	0.58
11,000	011000	0.44	0.44	0.44	0.44	0.44	0.44
6,900	006900	0.28	0.28	0.28	0.28	0.28	0.28
1,860	001860	0.08					
1,390	001390	0.06					
900	000900	0.04					
145	000145	0.01					
19	000019	0.00					
0	000000	0.00					
Max Candela (kCD), -30C to +50C		11	22	33	44	55	66
Max Current (A @ 12V @ 25C)		0.44	0.88	1.32	1.76	2.20	2.64

Beacon On continuous current (A @ 12V)*	0.010	0.010	0.010	0.010	0.010	0.010
Beacon Off continuous current (A @ 12V)	0.010	0.010	0.010	0.010	0.010	0.010



Indicates the approximate crossover region between all optics active and one optic active.

** This current is continuously drawn during and between flashes, irrespective of the programmed intensity. It is additional to the intensity-related currents in the table above it.*

***The beacon intensity programming is not limited to the values shown. Any value can be set within the specified range and within the available precision of the programming code.*

VRL-74 Range Light Performance Table 12° x 3°							Jun 2017
Intensity (Cd) **	Prog Code (six digits) **	YELLOW 366 4x1 Spreader					
		Current (A) @25C, 12V					
		VRL-74- 141 1-optic product	VRL-74- 241 2-optic product	VRL-74- 341 3-optic product	VRL-74- 441 4-optic product	VRL-74- 541 5-optic product	VRL-74- 641 6-optic product
58,200	058 200	-	-	-	-	-	2.64
55,000	055 000	-	-	-	-	-	2.49
48,500	048 500	-	-	-	-	2.20	2.20
45,700	045 700	-	-	-	-	2.07	2.07
38,800	038 800	-	-	-	1.76	1.76	1.76
33,000	033 000	-	-	-	1.50	1.50	1.50
29,100	029 100	-	-	1.32	1.32	1.32	1.32
22,000	022 000	-	-	1.00	1.00	1.00	1.00
19,400	019 400	-	0.88	0.88	0.88	0.88	0.88
14,500	014 500	-	0.66	0.66	0.66	0.66	0.66
9,700	009 700	0.44	0.44	0.44	0.44	0.44	0.44
3,664	003 664	0.17	0.17	0.17	0.17	0.17	0.17
1,740	001 740	0.08	0.08	0.08	0.08	0.08	0.08
1,640	001 640	0.08					
3,664	003 664	0.17					
1,390	001 390	0.07					
145	000 145	0.01					
16	000 016	0.00					
0	000 000	0.00					
Max Candela (kCD), -30C to +50C		9.7	19.4	29.1	38.8	48.5	58.2
Max Current (A @ 12V @ 25C)		0.44	0.88	1.32	1.76	2.20	2.64

Beacon On continuous current (A @ 12V)*	0.010	0.010	0.010	0.010	0.010	0.010
Beacon Off continuous current (A @ 12V)	0.010	0.010	0.010	0.010	0.010	0.010



Indicates the approximate crossover region between all optics active and one optic active.

** This current is continuously drawn during and between flashes, irrespective of the programmed intensity. It is additional to the intensity-related currents in the table above it.*

***The beacon intensity programming is not limited to the values shown. Any value can be set within the specified range and within the available precision of the programming code.*

VRL-74 Range Light Performance Table 15° x 3°							Jun 2017
Intensity (Cd) **	Prog Code (six digits) **	YELLOW 366 5x1 Spreader					
		Current (A) @25C, 12V					
		VRL-74- 151 1-optic product	VRL-74- 251 2-optic product	VRL-74- 351 3-optic product	VRL-74- 451 4-optic product	VRL-74- 551 5-optic product	VRL-74- 651 6-optic product
40,400	040 400	-	-	-	-	-	2.64
37,700	037 700	-	-	-	-	-	2.46
33,600	033 600	-	-	-	-	2.20	2.20
29,100	029 100	-	-	-	-	1.90	1.90
26,900	026 900	-	-	-	1.76	1.76	1.76
22,000	022 000	-	-	-	1.44	1.44	1.44
20,200	020 200	-	-	1.32	1.32	1.32	1.32
17,300	017 300	-	-	1.13	1.13	1.13	1.13
13,400	013 400	-	0.88	0.88	0.88	0.88	0.88
9,700	009 700	-	0.63	0.64	0.64	0.64	0.64
6,700	006 700	0.44	0.44	0.44	0.44	0.44	0.44
3,664	003 664	0.24	0.24	0.24	0.24	0.24	0.24
1,205	001 205	0.08	0.08	0.08	0.08	0.08	0.08
1,135	001 135	0.08					
900	000 900	0.06					
488	000 488	0.03					
145	000 145	0.01					
11	000 011	0.00					
0	000 000	0.00					
Max Candela (kCD), -30C to +50C		6.7	13.4	20.2	26.9	33.6	40.4
Max Current (A @ 12V @ 25C)		0.44	0.88	1.32	1.76	2.20	2.64

Beacon On continuous current (A @ 12V)*	0.010	0.010	0.010	0.010	0.010	0.010
Beacon Off continuous current (A @ 12V)	0.010	0.010	0.010	0.010	0.010	0.010



Indicates the approximate crossover region between all optics active and one optic active.

** This current is continuously drawn during and between flashes, irrespective of the programmed intensity. It is additional to the intensity-related currents in the table above it.*

***The beacon intensity programming is not limited to the values shown. Any value can be set within the specified range and within the available precision of the programming code.*

VRL-74 Range Light Performance Table 18° x 3°							Jun 2017
Intensity (Cd) **	Prog Code (six digits) **	YELLOW 366 6x1 Spreader					
		Current (A) @25C, 12V					
		VRL-74- 161 1-optic product	VRL-74- 261 2-optic product	VRL-74- 361 3-optic product	VRL-74- 461 4-optic product	VRL-74- 561 5-optic product	VRL-74- 661 6-optic product
36,000	036 000	-	-	-	-	-	2.64
33,600	033 600	-	-	-	-	-	2.46
30,000	030 000	-	-	-	-	2.20	2.20
26,900	026 900	-	-	-	-	1.97	1.97
24,000	024 000	-	-	-	1.76	1.76	1.76
22,000	022 000	-	-	-	1.61	1.61	1.61
18,000	018 000	-	-	1.32	1.32	1.32	1.32
14,500	014 500	-	-	1.06	1.06	1.06	1.07
12,000	012 000	-	0.88	0.88	0.88	0.88	0.88
9,700	009 700	-	0.71	0.71	0.71	0.71	0.71
6,000	006 000	0.44	0.44	0.44	0.44	0.44	0.44
3,664	003 664	0.27	0.27	0.27	0.27	0.27	0.27
1,070	014 500	0.08	0.08	0.08	0.08	0.08	0.08
1,010	012 500	0.08					
900	000 900	0.07					
488	000 488	0.04					
145	000 145	0.01					
10	000 010	0.00					
0	000 000	0.00					
Max Candela (kCD), -30C to +50C		6.0	12.0	18.0	24.0	30.0	36.0
Max Current (A @ 12V @ 25C)		0.44	0.88	1.32	1.76	2.20	2.64

Beacon On continuous current (A @ 12V)*	0.010	0.010	0.010	0.010	0.010	0.010
Beacon Off continuous current (A @ 12V)	0.010	0.010	0.010	0.010	0.010	0.010



Indicates the approximate crossover region between all optics active and one optic active.

** This current is continuously drawn during and between flashes, irrespective of the programmed intensity. It is additional to the intensity-related currents in the table above it.*

***The beacon intensity programming is not limited to the values shown. Any value can be set within the specified range and within the available precision of the programming code.*

APPENDIX B.2 VRL-91 Optics

The VRL-91 product is available with 3° x 3° primary optics (defined at 50% intensity points). Note that all optics in a VRL-91 product will always project parallel to each other. i.e. the widest divergence that can be ordered for a VRL-91 product is the same as the widest divergence available from a primary lens.

Each VRL-91 product's programmable intensity range is designed for the color and number of optics ordered. The beacon should be programmed for the appropriate intensity desired for the specified color.

Appendix B.2.1 VRL-91 GREEN Intensity Settings And Currents

VRL-91 Range Light Performance Table 3° x 3°		Jun 2017
Intensity (Cd) **	Prog Code (six digits) **	GREEN 271 (Rectangular Beam) Current (A) @25C, 12V
		1-optic
276,000	276 000	2.1
250,075	250 075	1.9
205,455	205 455	1.5
168,615	168 615	1.2
138,220	138 220	0.97
113,100	113 100	0.67
75,580	075 580	0.45
62,000	062 000	0.36
50,200	050 200	0.30
3,664	003 664	0.022
1,390	001 390	0.008
1,232	001 232	0.007
0	000 000	0
Max Candela (kCD), -30C to +50C		276.0
Max Current (A @ 12V @ 25C)		2.1
Beacon On continuous current (A @ 12V)*		0.010
Beacon Off continuous current (A @ 12V)		0.010

* This current is continuously drawn during and between flashes, irrespective of the programmed intensity. It is additional to the intensity-related currents in the table above it.

**The beacon intensity programming is not limited to the values shown. Any value can be set within the specified range and within the available precision of the programming code.

Appendix B.2.2 VRL-91 WHITE Intensity Settings And Currents

VRL-91 Range Light Performance Table 3° x 3°		Jun 2017
Intensity (Cd) **	Prog Code (six digits) **	WHITE 473 (Rectangular Beam)
		Current (A) @25C, 12V
		1-optic
500,000	500 000	2.4
369,360	369 360	1.75
276,000	276 000	1.25
250,075	250 075	1.1
205,455	205 455	0.9
168,615	168 615	0.57
138,220	138 220	0.46
113,100	113 100	0.38
75,580	075 580	0.25
62,000	062 000	0.21
50,200	050 200	0.17
3,664	003 664	0.012
1,667	001 667	0.005
0	000 000	0
Max Candela (kCD), -30C to +50C		500.0
Max Current (A @ 12V @ 25C)		2.4
Beacon On continuous current (A @ 12V)*		0.010
Beacon Off continuous current (A @ 12V)		0.010

* This current is continuously drawn during and between flashes, irrespective of the programmed intensity. It is additional to the intensity-related currents in the table above it.

**The beacon intensity programming is not limited to the values shown. Any value can be set within the specified range and within the available precision of the programming code.

Appendix B.2.3 VRL-91 RED Intensity Settings And Currents

VRL-91 Range Light Performance Table 3° x 3°		Jun 2017
Intensity (Cd) **	Prog Code (six digits) **	RED 171 (Triangular Beam) Current (A) @25C, 12V
		1-optic
136,000	136 000	1.2
113,100	113 100	1.0
75,580	075 580	0.60
62,000	062 000	0.47
50,200	050 200	0.37
3,664	003 664	0.027
1,390	001 390	0.010
540	000 540	0.004
0	000 000	0
Max Candela (kCD), -30C to +50C		136.0
Max Current (A @ 12V @ 25C)		1.2
Beacon On continuous current (A @ 12V)*		0.010
Beacon Off continuous current (A @ 12V)		0.010

* This current is continuously drawn during and between flashes, irrespective of the programmed intensity. It is additional to the intensity-related currents in the table above it.

**The beacon intensity programming is not limited to the values shown. Any value can be set within the specified range and within the available precision of the programming code.

Appendix C BEACON Specifications
Appendix C.1 VRL-74 BEACON SPECIFICATIONS

Optical

Light Source	High-Intensity Light-Emitting Diodes Operating temperature controlled to protect LEDs
Colors Available	Red, Green, White, Yellow IALA Recommendation E-200-1 part1
Intensity	See Appendix B IALA Recommendation E-122(2001) & E-200-3 Part 3 (2008)
Intensity Settings	'Peak intensity during the flash' programming. Multiple levels set via TViR programming
Flash Characters	246 standard characters plus one custom character
Divergence	$\pm 1.5^\circ$ vertical, $\pm 1.5^\circ$ horizontal, measured at 50% of specified intensity; with X spreaders fitted giving $\pm (1.5 \times X)^\circ$ horizontal, measured at 50% of specified intensity.
Chromaticity Co-ordinates	Red 0.68<x<0.71, 0.29<y<0.32 White 0.28<x<0.37, 0.28<y<0.39 Green 0.015<x<0.26, 0.72<y<0.80 Yellow 0.52<x<0.60, 0.39<y<0.46

Appendix C.2 VRL-91 BEACON SPECIFICATIONS

Optical

Light Source	High-Intensity Light-Emitting Diodes Operating temperature controlled to protect LEDs
Colors Available	Red, Green, White IALA Recommendation E-200-1 part1
Intensity	See Appendix B IALA Recommendation E-122(2001) & E-200-3 Part 3 (2008)
Intensity Settings	'Peak intensity during the flash' programming. Multiple levels set via TViR programming
Flash Characters	246 standard characters plus one custom character
Divergence	$\pm 1.5^\circ$ vertical, $\pm 1.5^\circ$ horizontal, measured at 50% of specified intensity.
Chromaticity Co-ordinates	Red 0.68<x<0.71, 0.29<y<0.32 White 0.28<x<0.37, 0.28<y<0.39 Green 0.015<x<0.26, 0.72<y<0.75

Appendix C.3 COMMON BEACON SPECIFICATIONS

Synchronization

Wire Synchronization	Negative transition signal at start of flash character. Default compatibility with Vega 12VDC products' sync feature.
	Max sink current 3.2mA @12V positive supply

Electrical

Voltage	10 to 30 VDC maximum, nominal 12.0 VDC or 24.0VDC.
Low Voltage Cut Out	Programmable low voltage cut off threshold (the defaults are set for 12VDC operation).
Current between Flashes	Refer to Appendix B tables.

Materials for Beacon

Lens	Machined cast acrylic
Cover	Xylex X8300 UV-stabilized
Heat sink	Anodized marine grade aluminum
Frame	Anodized marine grade aluminum
Bird Spikes	316 Stainless steel.
Sealing	O rings

Environment

Temperature	-30°C to +50°C
Intrusion Protection	IP67
Design Icing Load	20 kg/square meter on external surface
Design Wind Speed	90 knots (170kph)
Ultra-Violet Radiation	All external materials are UV resistant
Shock	MIL-STD-202G, Method 213B, Cond H. 70g shock vertical and horizontal
Vibration	MIL-STD-202G, Method 204D Cond B, peak value of 5g in all directions
Electromagnetic Interference	EN55015:2006; 2007:Amd1; 2009:Amd2 radiated emissions EN61000-4-2:2001 Electrostatic Discharge Immunity, Level 4 EN61000-4-3: 2002 Radiated Immunity, Class 1 EN61000-4.5:1995 Class 3 Surge Immunity, 0.5kV lead-to-lead FCC 47 CFR Section15 Class A

Programming

Vega Remote02 Infra-red programmer

Design Life

12 years

Warranty

1 year. See Vega warranty terms

TVIR Programmer

Coding Scheme:	RC5 code with center frequency 36.7 kHz
Dimensions:	87mm x 41mm x 6.5mm
Weight:	18gms
Power Supply:	1 x 3V lithium coin cell battery, CR2025 type

Battery Replacement on TVIR Programmer

Place the remote face down, and push the latch on the battery holder towards the center of the programmer case, while at the same time levering the slot on the battery holder outward as shown in the illustration below.

- (1) Pull the battery holder out of the case.



- (2) Remove the old battery and insert a new one, ensuring that the + side of the battery is facing upwards as shown.



- (3) Insert the battery holder into the programmer case, and press it until the latch clicks into place.